

## DIFFERENTIAL PRESSURE LOW PRESSURE AND VACUUM

ANC4B 316 stainless steel or black anodised aluminium switchcase to IP66 standards.

Calibrated adjustment scale.

Settings from 0.25 mBar to 10.5 Bar.

Single or dual microswitch option.

Wetted parts NACE MR-01-75 compliant.

**ATEX Flameproof version**

CE Ⓜ II2GD Exd IIB + H<sub>2</sub>

T6 Ta -60 to +75°C, T5 Ta +90°C

ExtD A21 IP66

T85°C Ta -50 to +75°C, T100°C Ta +90°C

**ATEX Intrinsically safe version**

CE Ⓜ II1G Exia IIC T6 Ta -50 to +78°C

T5 Ta +93°C, T4 Ta +128°C

II1D ExiaD 20 IP66 T200°C

Ta -50 to +70°C

(For resistor certification refer to page 45)

## DPF266 & DPF296, PF266 & VF266 ATEX Exd, Exia AND INDUSTRIAL DIFFERENTIAL PRESSURE, LOW PRESSURE AND VACUUM SWITCH



This range has been used to monitor filter blockage and air movement through ducting worldwide and has been specified extensively for offshore applications. Incorporating a diaphragm and two sealing Belloframs the switch offers reliable switching action when a differential pressure is required to be sensed. They can, by venting either the HP or LP connection, be used as a **low pressure** or **vacuum** switch. The DPF296 can be offered for high equalised static pressures up to 140 Bar, ranges are detailed below. Resistors can be incorporated for 'end of line' and short circuit monitoring. For specification and introduction to the Titan switch range refer to pages 44 & 45.

ADJUSTMENT RANGE (BAR D)	MAXIMUM WORKING PRESSURE EQUALISED (BAR D)	MAXIMUM WORKING PRESSURE ONE SIDED (BAR G)	DEADBAND FIXED (mBAR G)	SPRING CODE	DIAPHRAGM CODE
1.75 - 8.5	28	14	100 - 400	W	01
0.5 - 5.5	28	14	70 - 380	P	01
0.3 - 1.1	28	14	40 - 90	R	01
125 - 725mbar	10	7	10 - 75	G	02
50 - 250mBar	10	7	5.0 - 27.5	G	03
25 - 75mBar	10	7	4.2 - 7.5	T	03
15 - 55mBar	* 0.5	0.35	5.0 - 7.5	B	08
4 - 16mBar	* 0.5	0.35	0.75 - 2.0	R	08
1 - 5mBar	* 0.5	0.35	0.4 - 0.75	T	08
0.4 - 4.4mBar	Viton Diaphragm / 0.5	0.35	0.05 - 0.25	T	48
0.25 - 4.25mBar	Nitrile Diaphragm / 0.5	0.35	0.05 - 0.25	T	28

\* Max. equalised pressure on these ranges can be specified up to 3.5 Bar

### ADJUSTMENT RANGES - DPF296

1.0 - 5.0	140	28	<900	G	F18
3.5 - 10.5	140	28	<1500	W	F27



DIMENSIONS IN MILLIMETRES

TYPICAL ARRANGEMENT DRAWING FOR REFERENCE ONLY

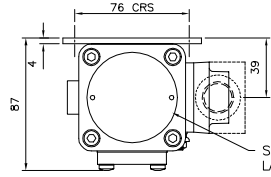

SWITCH APPROVALS LABEL

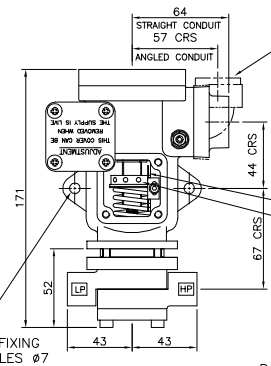
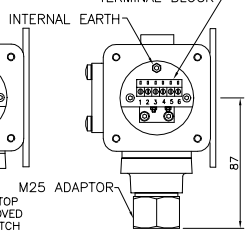
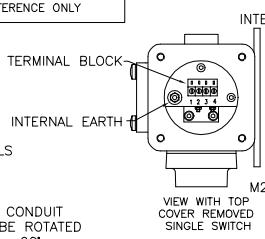

ALTERNATIVE CONDUIT ENTRY MAY BE ROTATED THROUGH 4 x 90° RIGHT OR LEFT HAND ENTRY AVAILABLE

EXTERNAL EARTHING CONNECTION

SCALE ADJUSTING NUT

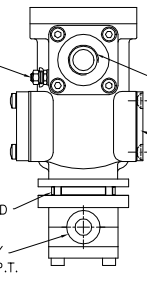

VIEW WITH TOP COVER REMOVED TWIN SWITCH

DPF266 1" DIFFERENTIAL PRESSURE SWITCH

INDUCTIVE RATING  
5 AMP 250V AC  
3 AMP 30V DC

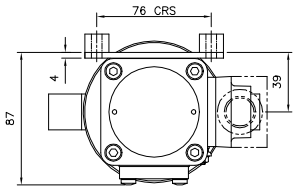

NOTE-DIMENSIONS AS 1" DP UNLESS SHOWN OTHERWISE

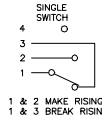

1 & 2 MAKE RISING  
1 & 3 BREAK RISING

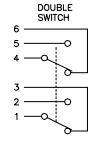

1 & 2 MAKE RISING  
1 & 3 BREAK RISING  
4 & 5 MAKE RISING  
4 & 6 BREAK RISING

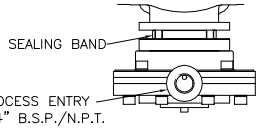
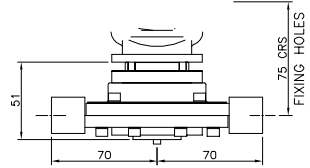

DPF266 2" & 3" DIFFERENTIAL PRESSURE SWITCH

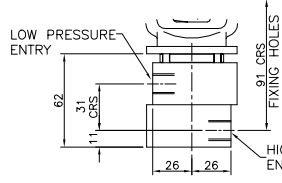

NOTE-DIMENSIONS AS 1" DP UNLESS SHOWN OTHERWISE

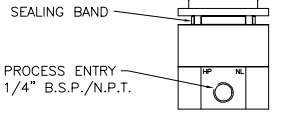

DPF296 DIFFERENTIAL PRESSURE SWITCH

TITAN DP B

DIMENSIONS IN MILLIMETRES

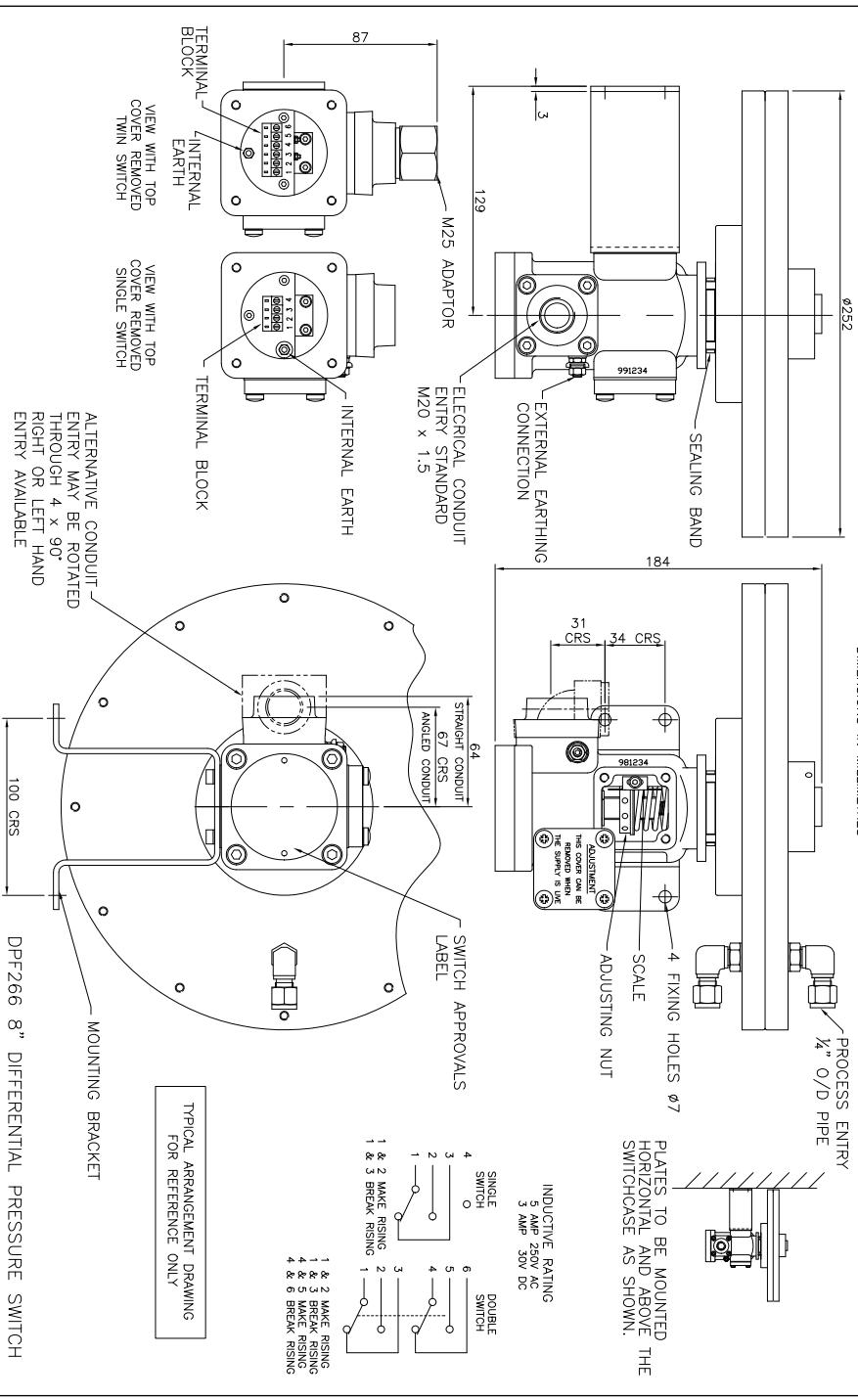

# TITAN (XPB) ATEX Exd, Exia INDUSTRIAL SWITCHES

## INTRODUCTION

The Titan **pressure, differential pressure, temperature, level and flow** switches are designed for use in environments where explosive gases and dust can be present (e.g. Gas fields, Oil rigs and Chemical plants etc.) and have been ATEX certified for CAT 1 Exia IIC T6, T5 & T4 and CAT 2 Exd IIB +H<sup>2</sup> T6 & T5.

These switches are manufactured from a high quality casting which offers robust construction and protection to IP66 for use within heavily polluted industrial and marine environments. A special feature of the instruments is the separation of the flameproof and adjustment compartments allowing for safe on-site adjustment of the set point with power on and the switch in operation.

The TITAN Exd certified switches must be installed in accordance with BS EN 60017-14. The certification allows for mounting against a wall or bulkhead with the minimum flamepath distances specified not being applicable.

## CALIBRATION

The design features a simple form of calibration adjustment against a scale plate. This allows users to either order units with a specific setting, or stock a mid range setting and then adjust to suit the application. This can be set safely with the switch supply live. On removal of the adjustment cover the adjusting ring can be turned with a small Tommy bar or Allen key. The setting is read from the centre of the red pointer ring against the calibrated scale plate. Rotation to the left will increase the set point and to the right decrease the set point. The adjustment mechanism incorporates a friction device to ensure set point will not change under vibration conditions.

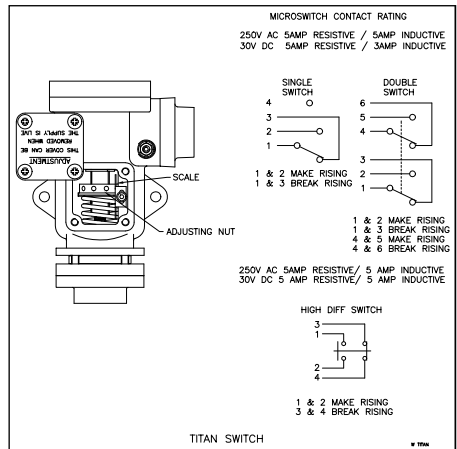

When we are requested to supply switches set at a specific point we can guarantee setting accuracy of less than 2%.



TITAN Exd



TITAN Exia (IS)

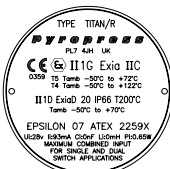

TITAN Exia (IS)  
WITH RESISTORS



The Pyropress Engineering Company Ltd.  
Bell Close, Newnham Industrial Estate,  
Plymouth, Plymouth. Devon PL7 4JH England.  
Tel: +44 (0)1752 339866  
Fax: +44 (0)1752 336681  
E-mail: sales@pyropress.com  
Website: www.pyropress.com  
Revision: E 04/10

## TECHNICAL SPECIFICATION

**Switchcase and covers** : ANC4B 316 stainless steel or black anodised aluminium.

**Microswitch** : 1 x SPCO/SPDT or 2 x SPCO/SPDT gold plated silver contacts. Dual switches are mechanically linked to provide DPDT switching action, reset of switches could be up to 3% apart. Dual microswitches may increase deadband by a factor of two.

### **Microswitch rating**

5 Amps @ 250 VAC resistive and inductive.

5 Amps @ 30VDC resistive, 3 Amps @ 30 VDC inductive.

**Electrical connections** : Terminals suitable for cable 0.5 - 2.5 mm<sup>2</sup>.  
(Max 1.5mm<sup>2</sup> for dual microswitch version)

**Electrical Conduit Entry** : M20 x 1.5 straight or angled entry. ½” NPT via adaptors

**Environmental Protection** : Switches have been tested and certified by an external test house to IP66 in accordance with BS EN 60529 : 1992.

**Vibration and shock parameters** : Switches were subjected to Ministry of Defence Type Approval System Test Vibration DGS 350 Paras 0602 & 0603. Shock – BR3021.

**Temperature Limitations** : Pressure, Vacuum and Differential Pressure

**Ambient** : -50 to +85°C (standard) -60°C to 125°C (special).

**Process** : Diaphragm actuated\* -50 to +90°C (Nitrile) or -20 to +150°C (Viton).  
Piston actuated -40 to 120°C (Nitrile) or -20 to +150°C (Viton).

**Storage\*** : -60 to +85°C.

\* Unless otherwise stated

(for temperature, level and flow switches please refer to specific pages).

**Certification** : Switches are ATEX certified for gas and dust hazardous areas.

**Exd Flameproof** (with or without resistors)

CE Ex II2GD Exd IIB + H<sub>2</sub> T6 Ta -60 to +75°C, T5 Ta +90°C

ExtD A21 IP66 T85°C Ta -50 to +75°C, T100°C Ta +90°C

Special conditions for safe use. 1) No modifications must be made to the flamepaths of the unit without consultation of the drawings listed on the certificate. 2) If temperature of the cable entry could exceed 70°C, suitably rated cable must be selected based on the Tmax shown above.

**Exia Intrinsically Safe** (without resistors)

CE Ex II1G Exia IIC T6 Ta -50 to +78°C, T5 Ta +93°C, T4 Ta +128°C

II1D ExiaD 20 IP66 T200°C Ta -50 to +70°C

**Exia Intrinsically Safe** (with resistors)

CE Ex II1G Exia IIC T5 Ta -50 to +72°C, T4 Ta +122°C

II1D ExiaD 20 IP66 T200°C Ta -50 to +70°C

Special conditions for safe use. (Category 1, Zone 0) Aluminium may only be used when the ignition hazardous assessment shows that there is not risk of ignition from incandive, impact or abrasion sparks.

**Accuracy** : +/-1% at 20°C