

MEDIUM PRESSURE

ANC4B 316 stainless steel or black anodised aluminium switchcase.

IP66/IP67 certified housing.

SIL2 - IEC61508 proven reliability.

Calibrated adjustment scale.

Pressure Settings from 100 mBar to 12.4 Bar.

Single or dual microswitch option. Adjustable deadband option.

Wetted parts NACE MR-01-75 compliant.

Manual reset pushbutton option.

ATEX Certified Option

CE  IIIG Ex ia IIC

T6 Tamb -50 to +78°C

T5 Tamb -50 to +93°C

T4 Tamb -50 to +128°C

P1100 & P1200 GUARDIAN INDUSTRIAL & ATEX Exia CERTIFIED PRESSURE SWITCH



The standard range represents the basic models to cover pressure applications for settings of between 0.1 and 12.4 bar (2 to 180 PSI). Dual microswitch and adjustable differential options are available as detailed on the opposite page. For specification and introduction to the Guardian switch range refer to pages 10 & 11.

STANDARD NITRILE DIAPHRAGM

The fitting of a Viton diaphragm or dual microswitches may increase the deadband by a factor of two. Microswitches other than shown below may also increase the deadband.

ADJUSTMENT RANGE (BAR)	ADJUSTMENT RANGE (PSI)	MAX WORKING PRESS. (BAR)		DEADBAND (BAR)	DIAPHRAGM CODE	SPRING CODE
		NITRILE	VITON			
9 - 19	130 - 270	24	50	<1.9	15	R
4 - 12	60 - 80	24	50	<1.2	15	0
2 - 6	30 - 90	16	40	<0.6	21	0
1 - 3	15 - 45	8	30	<0.3	30	0
0.1 - 1.7	2 - 24	8	30	<0.2	30	1
0.3 - 3.1	5 - 45	8	30	<0.3	30	2
0.6 - 6.2	10 - 90	16	40	<0.6	21	2
1.2 - 12.4	20 - 180	24	50	<1.3	15	2

PART NUMBER BREAKDOWN				PROCESS ENTRY ORIENTATION S = STRAIGHT ENTRY - BOTTOM A = ANGLED ENTRY - SIDE	
P11 : CASE MOUNTED - STANDARD FEMALE PROCESS CONNECTION P12 : STEM MOUNTING MALE PROCESS CONNECTION	DIAPHRAGM A = NITRILE B = VITON - STD	SPRING CODE SEE RANGE SHEET	DIAPHRAGM CODE SEE RANGE SHEET	WETTED PARTS S = 316 ST. ST. M = MONEL	E = 2" STANDPIPE BRACKET
ANODISED ALUMINIUM CASE AS STANDARD IF ST. STEEL REQUIRED PREFIX "S"	↓ ↓ ↓ ↓ ↓ ↓ ↓ ↓ ↓ ↓				X = STD
(S) P 1 1 0 1 / A 0 1 0 N 3 0 / S S 1 X					
MICROSWITCH OPTIONS 01 = SINGLE SWITCH 02 = DUAL SWITCHES 03 = USE 01 04 = USE 02 05 = SINGLE FOR EXIA 06 = DUAL FOR EXIA	PROCESS CONNECTION TYPE P11: 10 - STANDARD FEMALE P12: 22 = 1/2" BSP.P MALE 24 = 1/2" NPT MALE 61 = 1" BSP.P MALE FLUSH DIAPHRAGM ONLY AVAILABLE ON 1.2 - 12.4 BAR WITH MAX OF 16 BAR		N = STANDARD ADJUSTER A = SECONDARY ADJUSTER (FOR DUAL SETTING AND ADJUSTABLE DEADBAND)	PROCESS ENTRY SIZE FOR P1100 1 = 1/4" BSP.P FEMALE 2 = 1/4" NPT. FEMALE 5 = 1/2" BSP.P FEMALE 6 = 1/2" NPT. FEMALE FOR P12 (MALE) USE = 1	
ADJUSTABLE DEADBAND 07 = SINGLE SWITCH - STANDARD 08 = SINGLE SWITCH - USE FOR EXIA 09 = MANUAL AND AUTO (RESET RISING) 0A = MANUAL AND AUTO (RESET FALLING)	0C = MANUAL (RESET RISING) 0D = MANUAL (RESET FALLING) 0E = DUAL HIGH CURRENT DC 0M = SINGLE HIGH CURRENT DC SWITCHING		0K = DPDT MICROSWITCH PLEASE REFER TO MICROSWITCH RATINGS ON PAGE 11.		

SPECIFICATION

Wetted parts : 316 St. steel or Monel
Diaphragm : Nitrile or Viton
Pressure Limitations : Please refer to details opposite. All switches can be subjected to a full vacuum.

Process connections : 1/4" or 1/2" BSP.P or NPT female (bottom)
 1/4" BSP.P or NPT female (side)
 1/2" BSP.P or NPT male (bottom)

For detailed drawing showing options refer to Fig.1 page 21

EXAMPLE. Dual microswitches - if switch 1 is set at 10 Bar on a 4 - 12 Bar range switch 2 can be set at the same pressure or between 10.2 and 12.0 Bar with standard adjuster and between 10.7 and 14.5 bar with secondary adjuster. With the secondary adjuster fitted microswitches cannot be set together.

Note: 1) Lowest set point is always switch 1 on dual set point switches. 2) Adjustable deadband mechanism actuates on falling settings, therefore reset on rising pressure.

ADJUSTABLE DEADBAND SWITCHING LIMITS					DUAL MICROSWITCH ADJUSTMENT LIMITS			
MINIMUM DIFF AT BOTTOM OF RANGE (BAR)	MAXIMUM DIFF AT BOTTOM OF RANGE (BAR)	ADJUSTMENT RANGE (BAR) (FALLING SET POINTS ONLY) SWITCH 1	MINIMUM DIFF AT TOP OF RANGE (BAR)	MAXIMUM DIFF AT TOP OF RANGE (BAR)	SWITCH 2 RELATIVE TO SWITCH 1 MIN - (BAR) - MAX (STANDARD ADJUSTER)		SWITCH 2 RELATIVE TO SWITCH 1 MIN - (BAR) - MAX (SECONDARY ADJUSTER)	
1.1	3.5	4 - 12	1.6	3.7	0.2	2.0	0.7	4.5
0.5	2.5	2 - 6	0.7	3.5	0.08	1.0	0.3	2.8
0.3	1.7	1 - 3	0.45	2	0.05	0.35	0.17	1.2
0.15	0.55	0.1 - 1.7	0.25	0.75	NOT AVAILABLE		0.08	1.1
0.15	0.45	0.3 - 3.1	0.25	0.6			0.3	2.0
0.25	1.45	0.6 - 6.2	0.4	2.5			0.3	2.6
0.6	3.25	1.2 - 12.4	1.5	4			1.0	7.5

FIG. 1 TYPE P1000 GUARDIAN PRESSURE SWITCH

TYPICAL ARRANGEMENT DRAWING FOR REFERENCE ONLY

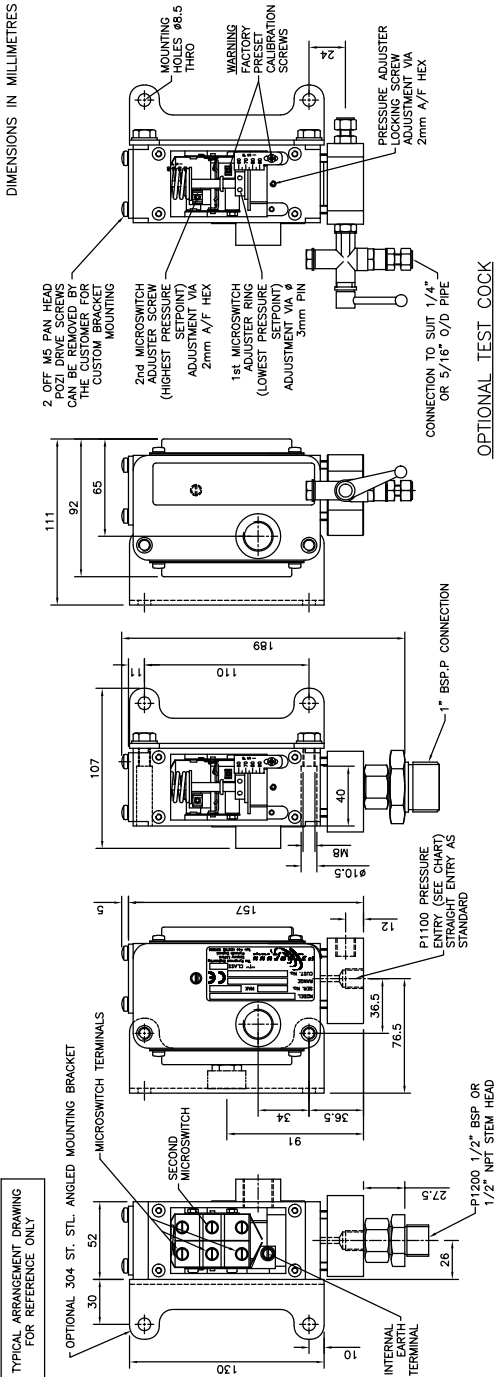

OPTIONAL TEST COCK

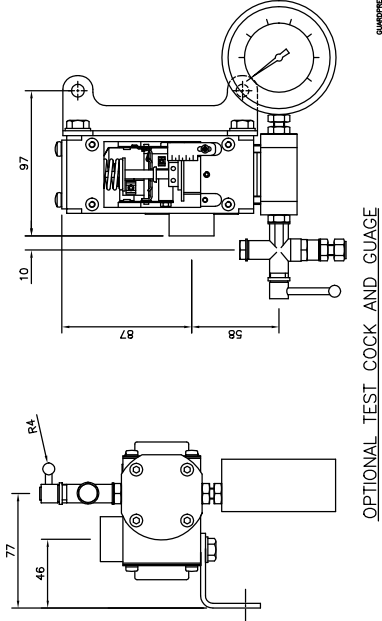

ENTRY THREAD SIZE
1/4" BSP STRAIGHT
1/4" NPT STRAIGHT
1/2" BSP STRAIGHT
1/2" NPT STRAIGHT
1/4" BSP ANGLED
1/4" NPT ANGLED

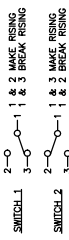

PART VIEW SHOWING ASSEMBLY OF SECONDARY ADJUSTER MECHANISM

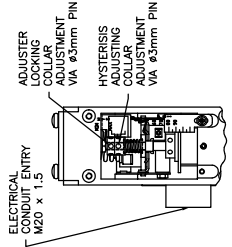

90° PRESSURE ENTRY MOUNTING POSITION

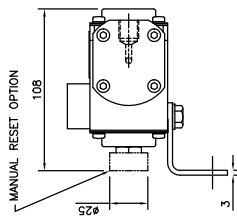

MICROSWITCH CONTACTS

GUARDIAN INDUSTRIAL & ATEX Exia SWITCHES

INTRODUCTION

The Guardian **pressure, differential pressure, temperature, level and flow** switches are a part of our extensive range of specialist process sensors. They utilise the expertise gained from over 50 years experience of designing and manufacturing control devices for industrial, marine and hazardous area applications.

These switches are constructed with either a robust aluminium or stainless steel enclosure. The aluminium casting is black anodised and supplied with 316 stainless steel covers. The stainless steel case is a natural finish. Covers are gasketed and sealed to achieve an environmental seal to IP66 & IP67 standards. The internals utilise a unique mechanism designed by the engineers at PYROPRESS to produce a wide range, low switching differential and excellent repeatability. This combined with a variety of microswitches, mountings and sensor options has produced a switch range suitable for all weatherproof and intrinsically safe applications.

CALIBRATION

The design features a simple form of calibration adjustment against a scale plate. This allows users to either order units with a specific setting, or stock a mid range setting and then calibrate to suit the application. Calibration is performed on the opposite side of the switch to the electrical connections, and can be set safely with the switch supply live. On removal of the adjustment cover a small grub screw can be loosened allowing the adjusting ring to be turned with a small Tommy bar or Allen key. The setting is read from the centre of the red indicating ring against the calibrated scale plate.

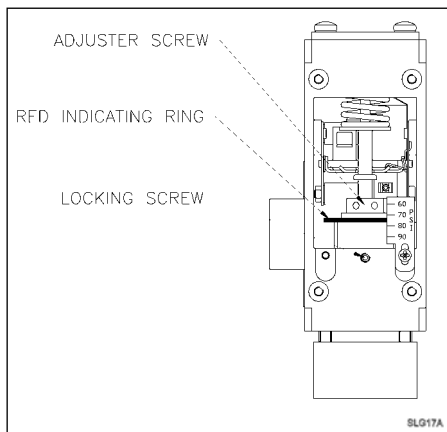

Calibration procedures for dual microswitches and adjustable switching differential switches are detailed on the operating and maintenance instructions supplied with each switch.

TECHNICAL SPECIFICATION

Switchcase and covers : ANC4B 316 stainless steel switchcase with 316 stainless steel covers or black anodised aluminium switchcase and 316 stainless steel covers. Optional 304 stainless steel mounting bracket.

Microswitch : SPCO/SPDT. Options include single or twin switch assemblies for simultaneous or separately adjustable set points, adjustable switching differential, manual reset and noble metal contacts for use on intrinsically safe circuits.

Microswitch rating

Standard microswitch : 6 Amps @ 480 V.AC
: 10 Amps @ 250 V.AC & 125 V.AC
: 5 Amps @ 30 V.DC & 0.5 Amps @ 125 V.DC
Adjustable deadband and high : 10 Amps @ 250 V.AC or DC
Current DC switching

Electrical Connections : Screwed terminals direct onto microswitch, suitable for cable up to 2.5 mm². (Manual reset microswitch is supplied with 6BA solder tags).

Electrical Conduit Entry : M20 x 1.5 straight entry. Adaptors are available.

Environmental Protection : Switches have been tested and certified by an external test house to IP66 in accordance with BS EN 60529 : 1992. In addition further internal tests confirm that the switchcase meets the requirements of IP67.

Vibration and shock parameters : Switches were subjected to Lloyds Register Type Approval System Test Specification No.1 Clause 130 Vibration Test 142 and shock tested to BS EN 60068-2-27 : 1987.

Temperature Limitations: Pressure, Vacuum and Differential Pressure.

Process : Diaphragm actuated unless otherwise stated -50 to +90°C (Nitrile) or -20 to +150°C (Viton). Piston actuated -40 to +120°C (Nitrile), or -20 to +150°C (Viton) or -60 to +150°C (PTFE). **Ambient :** -10 to +80 Deg.C.

Storage : -60 to +80°C. (For temp, level and flow refer to specific pages).

Certification: All switches are CE certified and marked in accordance with the following EU directives. Industrial : 2006/95/EC (Low Voltage Directive). Exia : 94/9/EC ATEX coded CE Ex II1G Exia IIC. CAT 1 (Zone 0) areas Special conditions for safe use. (Category 1, Zone 0) Aluminium may only be used when the ignition hazardous assessment shows that there is not risk of ignition from incensive, impact or abrasion sparks.

Accuracy: 1% @ 20°C.

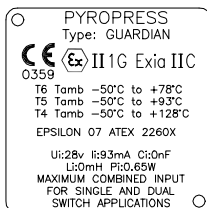

The Pyropress Engineering Company Ltd.
Bell Close, Newnham Industrial Estate,
Plympton, Plymouth. Devon PL7 4JH England.
Tel: +44 (0)1752 339866
Fax: +44 (0)1752 336681
E-mail: sales@pyropress.com
Website: www.pyropress.com
Revision: D 06/09