

## WORKING INSTRUCTIONS

### PERSEUS RANGE

This working instruction leaflet covers the following ranges of switches:  
PF/R61 Diaphragm Pressure Switch  
PF/R62 Diaphragm Pressure Switch  
PF/R61 Piston Pressure Switch  
PF/R62 Piston Pressure Switch

## INSTALLATION

### HEALTH AND SAFETY AT WORK ACT 1974

#### WARNING

Your attention is drawn to the electrical potential that will be present if the terminal cover is removed while the switch is connected to a live supply. The electrical supply must be isolated prior to removal of the terminal housing cover.

Similarly, on pressurised process systems, prior to removal of an instrument it should be isolated from the pressurised medium or the system pressure should be relieved. Precautions must be taken with regard to the possible operating temperatures present when performing adjustment.

The units should be specified, installed and operated by competent personnel, and their use must be limited to within the published specifications. (All hazardous area models must be installed in accordance with BS EN 60079-14).

Unauthorised modification, repair or operation outside the specified limits may invalidate the warranty. Servicing should be carried out by qualified personnel only.

On pressure devices, should pulsation or surges be anticipated, a suitable pressure snubber should be fitted.

## FAILURE HAZARD

#### Pressure switches.

Element/primary seal failure.

#### Metal Diaphragm.

In the event of the above the process medium will be prevented from entering and pressurising the main body by a secondary seal and will be vented to atmosphere via a vent hole.

#### Rubber Diaphragm.

In the event of the above the process medium can potentially enter the main body, but should be vented by the bleed hole and Gore-tex® filter located in the bottom of the adjustment chamber.

The process medium temperature should not be allowed to exceed that stated in the product data and under the "OPERATING TEMPERATURES" section in this document. If process temperatures in excess of those stated are possible, then the switch should be remote mounted via a length of tubing or pipe to ensure dissipation of heat.

## PROCESS CONNECTIONS

#### Pressure Switches

Various process entries are available, and the installation will vary dependent upon exact type. It is recommended that PTFE tape is used on tapered fittings and the use of the correct size bonded seal on parallel fittings. Suitable pipe sealant or flange gasket should be incorporated when installing to ensure a good leak free fit.

## MATERIALS

The materials of construction are as follows:  
Main Body – Black Anodised aluminium  
Terminal Cover – Black Anodised aluminium  
Wetted Parts - 316 stainless steel or inconel  
Pressure Seals – Viton® or Nitrile  
Environmental Seals - Nitrile  
External Fasteners - Stainless steel  
Internal Fasteners & Springs – Zinc plated carbon steel

## OPERATING TEMPERATURES

The operating temperatures restrictions for the **Perseus** series are as follows:

**Ambient:**  
Operational -50°C to +85°C

#### Ambient ('T' values as certified for hazardous areas)

ATEX II1G Exia IIC certified.  
Without resistors: -50°C to +78°C T6  
-50°C to +93°C T5  
-50°C to +128°C T4

With resistors: -50°C to +72°C T5  
-50°C to +122°C T4

ATEX II1D ExiaD 20 IP67 T200°C certified.  
With or without resistors: -50°C to +70°C

ATEX II2GD Exd IIC certified:  
-50°C to +74°C T6  
-50°C to +89°C T5

ATEX ExtD A21 IP67 T115°C certified.  
With or without resistors: -50°C to +74°C

**Storage:** -50°C to +85°C

#### Process:

PF61 & PF62  
Viton® -20°C to +150°C  
Nitrile -40°C to +120°C

## MOUNTING INSTRUCTIONS

The PF61, PF62 have been designed to be mounted in any orientation to suit, without affecting accuracy, set point or operation.

When installing direct mounting pressure switches, particular care should be taken to ensure the internal ¼" nipple is not loosened during the positioning or tightening procedure. If the unit is likely to be subjected to high shock levels or physical loads then additional supports should be incorporated.

## ELECTRICAL INSTALLATION

All models are supplied with a M20 conduit entry and this can be fitted with either a suitable gland or directly with conduit, to suit the installation.

Access to the terminals is via a removable front cover, though the electrical supply must be isolated prior to this activity.

Switch connection details are provided on the inside of the cover. This should be referred to when connecting to the terminal strip as the N.O. / N.C. terminal numbers vary dependant on whether the switch setting is rising or falling.

Terminals are suitable for cables, single or multi-strand, up to 2.5mm<sup>2</sup>.

Terminals for dual micro switches are only suitable for cables, single or multi-strand, up to 1.5mm<sup>2</sup>.

Options of 1 or 2 SPDT micro switches are available.

Note: Dual switches, if required, are mechanically linked to give a DPDT switching

action; reset of the switches could be up to 3% apart.

For specific wiring details please refer to product drawings on reverse.

It is the responsibility of the installer to ensure that the Perseus is not subjected to electrical parameters outside those stated and that suitable overload protection is provided.

The Perseus range is certified for installation in a CAT1 (Zone 0) environment, when supplied from an approved Intrinsically Safe Interface that is compatible with the following electrical parameters:

Ui: 28Vdc  
Ii: 93mA  
Pi: 0.65W  
Ci: 0 nF  
Li: 0mH

## SETTING & CALIBRATION

Adjustment of the switch set point may be carried out without isolating the electrical supply.

Prior to despatch, switches are subjected to a specified maximum static pressure and operation check and set to mid range. They can be pre-set at a specified value against a calibrated test instrument.

The switch has tamperproof adjustment accessed by removal of the adjustment chamber cover.

Turning the adjustment nut to the left to raise the set point or to the right to lower it carries out adjustment to the set point.

## ATEX CERTIFICATION

The PERSEUS range of switches comply with the following standards:  
Intrinsically Safe

EN60079-0: 2006, EN60079-11: 2007  
EN60079-26: 2004, EN61241-0: 2006  
EN61241-11: 2006

Flameproof.

EN60079-0: 2006, EN60079-1: 2007  
EN61241-0: 2006, EN61241-1: 2004

The equipment is designed to satisfy the requirements of Clause 1.2.7 of the Essential Health and Safety Requirements ANNEX II of directive 94/9/EC.

#### Conditions of certification apply:

Exia CAT1 Applications.

ATEX certification for CAT1 environments to the Non-electrical standard BS EN 13463-1:2001 Clause 8.2 states that:

Equipment manufactured from aluminium of greater than 10% by mass, are only suitable for CAT1 environments if, 'the ignition assessment shows that there is no risk from incandive friction, impact or abrasion sparks' reference to BS EN 1127-1:1998 Clause 6.4.4.

This product has been certified with an 'X' suffix, indicating it is the responsibility of the end user to carry out an assessment of the equipment and installation to establish that "no hazards due to mechanically generated sparks have been identified". This assessment is to be performed by a qualified person, legally responsible for the site/company safety.

Exd

The cable selected shall be capable of being used in temperatures up to 100°C.

Covers / Labels titled TYPE PERSEUS shall only be fitted to enclosures housing terminals

Covers / Labels titled TYPE PERSEUS/R shall only be fitted to enclosures housing resistors.

INTRINSICALLY SAFE LABEL  
Gas & Dust without resistors fitted.

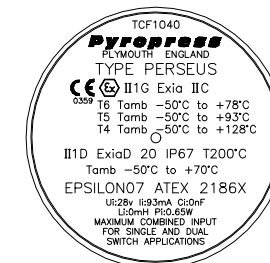

INTRINSICALLY SAFE LABEL  
Gas & Dust with resistors fitted.

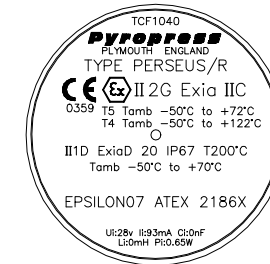

FLAMEPROOF LABEL  
Gas & Dust without resistors fitted.

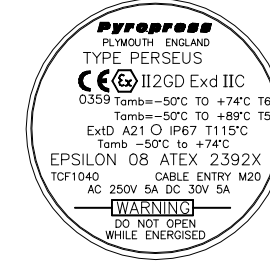

FLAMEPROOF LABEL  
Gas & Dust with resistors fitted.

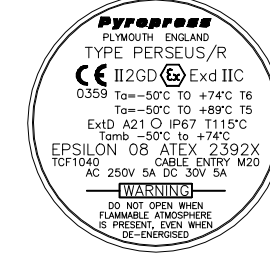

## PRESSURE EQUIPMENT DIRECTIVE

#### Pressure Equipment Directive (PED)

It is a requirement that all items of pressure equipment and assemblies with a maximum allowable pressure of over 0.5 bar be assessed under the PED. Installers should be aware and address the following sections of the PED.

These switches are classified as pressure accessories and are manufactured to Sound Engineering Practice (SEP) Art.3 (3). The CE mark is for compliance to the ATEX Directive or Low Voltage Directive.

#### Handling

Notice is drawn to the installation warnings with respect to: Closures and openings, access to the process entry when pressurised, and surface temperature.

#### Operation

In the case of fluids, which may become unstable and/or over-pressure (including surge), and/or over-temperature it is the installer's responsibility to ensure the device is operated within the published specifications.

#### Misuse

Notice is drawn to the installation warnings with respect to: Operation outside the specified limits in terms of over pressure or temperature.

#### Degradation of materials, Erosion

Notice is drawn to the requirements of routine maintenance and the expected working life of elastomeric materials.

#### Corrosion/Chemical attack

It is the installer's responsibility to ensure the selection of construction materials from the published specification is compatible with the operating medium.

#### Mounting, Piping

Provide adequate support, constraint, anchoring, alignment and pre-tensioning to prevent free movement and over-stressing of connections and flanges.

Consider condensation within piping and the means of drainage.

Consider potential damage from turbulence and vortices and make allowances for wear if appropriate.

Consider fatigue due to vibration.

Keep appropriate records for maintenance, inspection and repair.

#### Toxic, Flammable fluids

For group 1 gas and fluids (explosive or toxic nature) provide means to isolate and assess size for significant risk, protect as necessary.

#### Mechanical damage

Consider potential damage from objects such as vehicles, falling bodies or adjacent machinery and house or protect as necessary.

#### Fire

Consider potential damage in the event of external fire and house or protect as necessary.

#### Supply Fault

Consider the consequence of a power supply fault, failure or overload and protect as necessary.

## ROUTINE MAINTENANCE

Routine inspection of the installation should take place at regular intervals. It is recommended that the switch is checked and operated every 6 months. Electrical connections and covers should be checked periodically to tightness.

It is recommended that the 'O' rings and diaphragms (on pressure and flow switches) be renewed every 3-5 years, and micro switch assemblies every 5-10 years dependent upon equipment usage.

Gore-tex® filters fitted to the 3" and 4" low-pressure housings should be checked periodically for potential damage.

## FAULT DIAGNOSIS

If the Perseus series fails to operate, the following should be checked:

The installation of the switch

Electrical terminals are secure and tight

The micro switch function is correct

The mechanical function of the pushrod

Investigate for signs of process leakage

Investigate for signs of diaphragm failure (on pressure & differential pressure)

## SPARES & REPLACEMENT PARTS

Maintenance and overhaul of any type should only be carried out by qualified personnel, in accordance with current health and safety requirements.

Replacement microswitch assemblies and diaphragm kits are available.

There are four diaphragm kits available, either Viton®, Nitrile, 316 stainless steel or Inconel. Each kit contains a diaphragm and 'O' ring set (Nitrile & Viton®), specialist 'O' rings to be ordered separately.

Procedures for replacement of spare parts are as follows:

Note: After replacement of spare parts it is advised to connect the switch to a suitable test device & check

For:

(i) Leakage via a pressure test to the switches max working pressure.

(ii) The change over state of the microswitch contacts & if necessary re-adjust the main adjuster to obtain the original set point using a calibrated test gauge.

#### PF261 & PF262 Diaphragm Kit

Rubber Diaphragm - Remove 4 off M5 retaining screws securing the process entry, remove process entry & diaphragm. Replace; sealing 'O' ring located within the process entry, diaphragm and process entry. The 4 off M5 retaining screws should be re-assembled with a suitable thread sealant (PermaBond A131®) and tightened evenly to a torque setting of 6 Nm (4.4lb.ft).

3" & 4" Low Pressure - Remove M5 retaining screws securing the process entry, replace diaphragm (there is no sealing 'O' ring). Replace process entry taking care to align retaining screws with punched holes in diaphragm and re-tighten M5 screws evenly to an approximate torque of 6 Nm (4.4lb.ft).

Metal Diaphragm - The Process entry can be unscrewed from the body; this will require a 33mm A/F spanner or socket. Once removed the diaphragm and 'O' ring can be removed revealing the silicon insert. The silicon insert should be replaced to ensure that it is located correctly within the counter bore of the diaphragm ring. The diaphragm can be inserted on top of the silicon insert and is also located within a counter bore of the diaphragm ring. The correct 'O' ring to suit the medium should be located within the same counter bore as the diaphragm and the process entry can now be reassembled to the body. It is recommended that the process entry be secured with a suitable locking compound (Loctite 242) and torque to the correct setting of 20Nm. (15lb.ft).

#### PF61 & PF62 Piston 'O' ring kit.

Unscrew the Piston assembly from the switch head. Remove the adaptor / Dowty seal from the piston assembly.

Withdraw the piston; remove lock nut from the piston housing using a suitable pin spanner (Pyropress Part No. 16913). Remove the piston guide & piston support & outer 'O' ring from the housing. Remove the 'O' rings & backing rings (note order in which they are fitted) from the lock nut & piston support, after applying a suitable grease (Moly Slip®) fit the replacement 'O' rings & backing rings to the lock nut & piston support in correct order. Fit the replacement outer 'O' ring to the lock nut, locate the piston guide onto the outer 'O' ring / lock nut ensuring the centre hole chamfer is facing upwards, locate the piston support onto the guide, apply suitable grease (Moly Slip®) to piston & refit to assembly. Refit assembly into housing & tighten securely.

Replace the sealing band. Apply a suitable locking compound (Loctite® 242) to the threads of the housing & refit the piston assembly to the switch head. Apply a suitable locking compound (Loctite® 242) to the adaptor threads, replace the Dowty seal & screw into the piston assembly. Tighten securely.

A complete pre-assembled and leak tested replacement piston housing assembly is available; Contact Sales department for information.

#### Micro switch assemblies

Microswitch replacement for standard pressure switches is usually straightforward and can be achieved using standard calibration equipment.

#### Single or double micro switch assemblies

Remove 3 M3 cap head screws from PCB terminal mounting board and retain for reuse. Remove 2 M3 cap head screws from micro switch angle bracket and retain for reuse.

Withdraw micro switch assembly complete and discard.

Slide in replacement assembly and secure. Connect micro switch to a suitable circuit tester to monitor change over state of the micro switch contacts.

Adjust main adjuster to the original set point using a calibrated test gauge and appropriate test equipment.

#### Pyropress Engineering Company Ltd.

Sales Office: +44 (0) 1752 339866

Fax: +44 (0) 1752 336681

E-mail: [sales@pyropress.com](mailto:sales@pyropress.com)

Website: [www.pyropress.com](http://www.pyropress.com)

Revision 3C – 09/2010

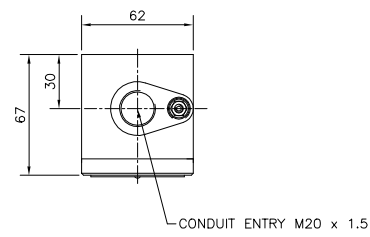

CONDUIT ENTRY M20 x 1.5

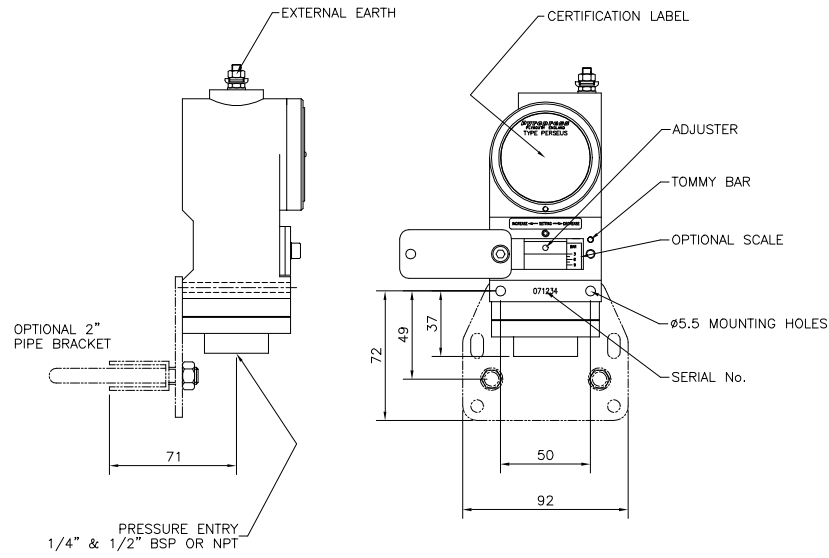
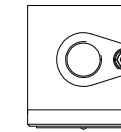
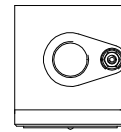

MEDIUM PRESSURE DIAPHRAGM SWITCH

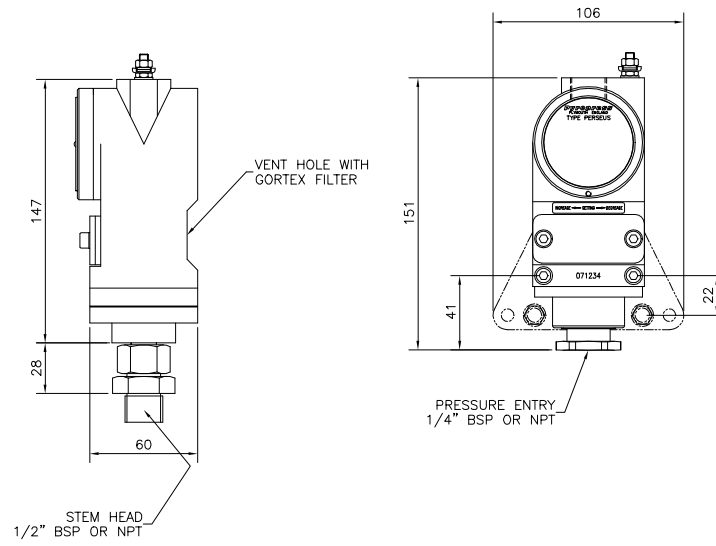

HIGH PRESSURE DIAPHRAGM SWITCH

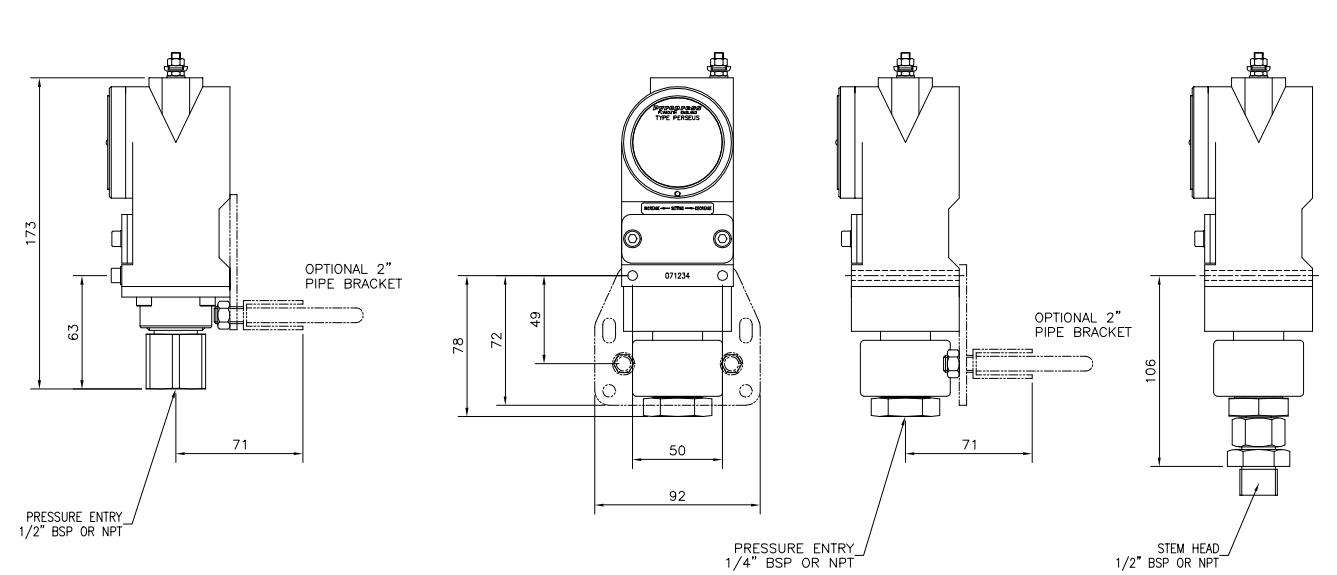

HIGH PRESSURE PISTON SWITCH

TERMINAL CONNECTIONS

HORIZONTAL LEVEL SWITCH

INDUCTIVE RATING

5 AMP 250V AC  
3 AMP 30V DC

WITH SWITCH MOUNTED IN POSITION SHOWN :-

- 1 & 2 CLOSE ON LOW LEVEL
- 1 & 3 CLOSE ON HIGH LEVEL
- 4 & 5 CLOSE ON LOW LEVEL
- 4 & 6 CLOSE ON HIGH LEVEL

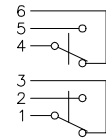

TERMINAL CONNECTIONS

VERTICAL LEVEL SWITCH

INDUCTIVE RATING

5 AMP 250V AC  
3 AMP 30V DC

TYPE A

- HIGH OR LOW LEVEL ALARM
- 1 & 2 and 4 & 5 MAKE ON HIGH LEVEL
- 2 & 3 and 4 & 6 BREAK BELOW HIGH LEVEL

TYPE B

- PUMP CONTROL
- 1 & 3 MAKE ON LOW LEVEL, REMAIN MADE UNTIL FLOAT REACHES HIGH LEVEL, THEN BREAK.
- 1 & 2 BREAK ON LOW LEVEL, REMAIN BROKEN UNTIL FLOAT REACHES HIGH LEVEL, THEN MAKE.

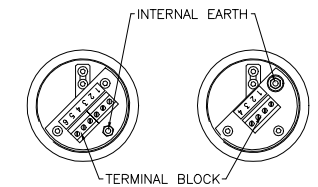
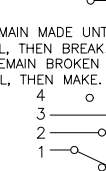
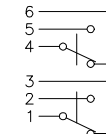

DOUBLE MICROSWITCH SINGLE MICROSWITCH  
PART VIEW OF TERMINAL CHAMBER WITH COVER REMOVED

MICROSWITCH CONTACT RATING

250V AC 5AMP RESISTIVE/ 5 AMP INDUCTIVE  
30V DC 5 AMP RESISTIVE/ 3 AMP INDUCTIVE

DOUBLE SWITCH

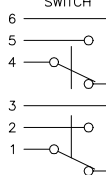

SINGLE SWITCH

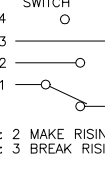

- 1 & 2 MAKE RISING
- 1 & 3 BREAK RISING
- 4 & 5 MAKE RISING
- 4 & 6 BREAK RISING

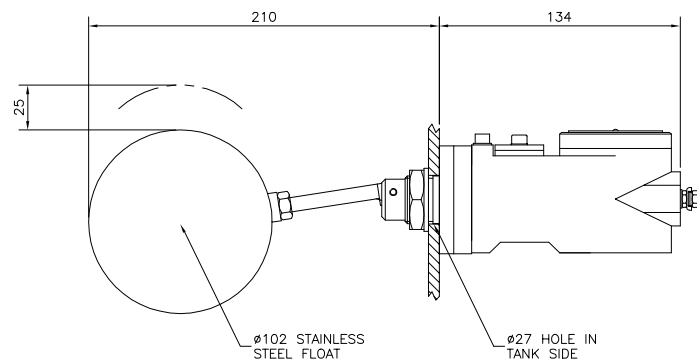

HORIZONTAL LEVEL SWITCH

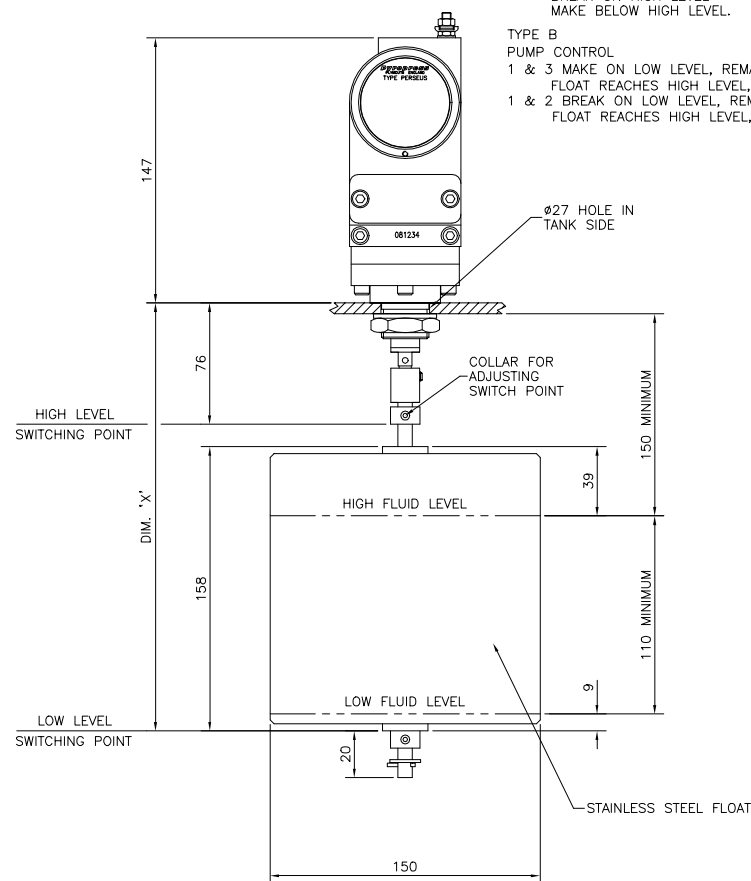

VERTICAL LEVEL SWITCH

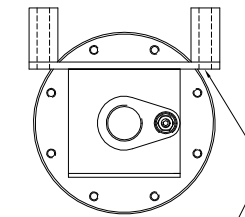
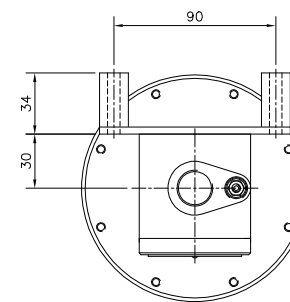

MOUNTING BRACKET  
2 HOLES Ø7

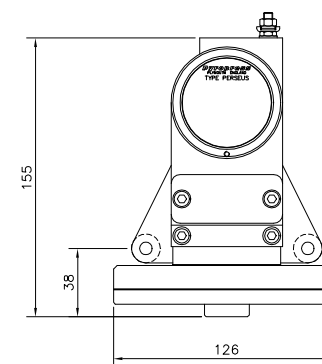

VIEWS SHOWING 4\"/>

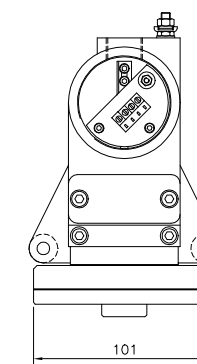

VIEWS SHOWING 3\"/>

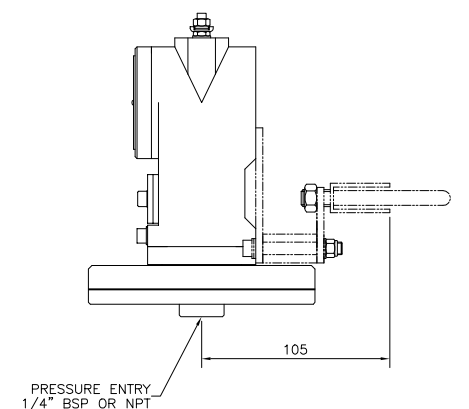

3\"/>

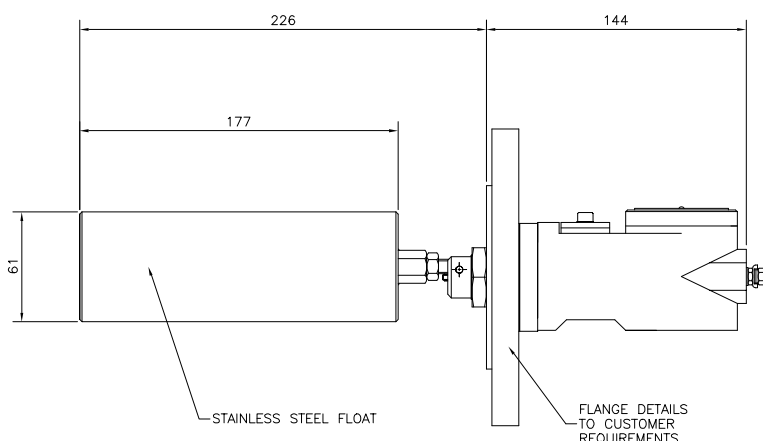

HORIZONTAL LEVEL SWITCH (SPECIAL)