

# TITAN FLUSH

## DIAPHRAGM PF261 TITAN ATEX/IECEX Exd, Exia CERTIFIED & INDUSTRIAL FLANGED PRESSURE SWITCH

This range incorporates a flush diaphragm and is suitable for settings up to 32 bar. It has been designed for use on processes involving mediums of a high viscosity level or containing suspended solids which would otherwise clog conventional recessed diaphragm models. Resistors can be incorporated for 'end of line' and short circuit monitoring.

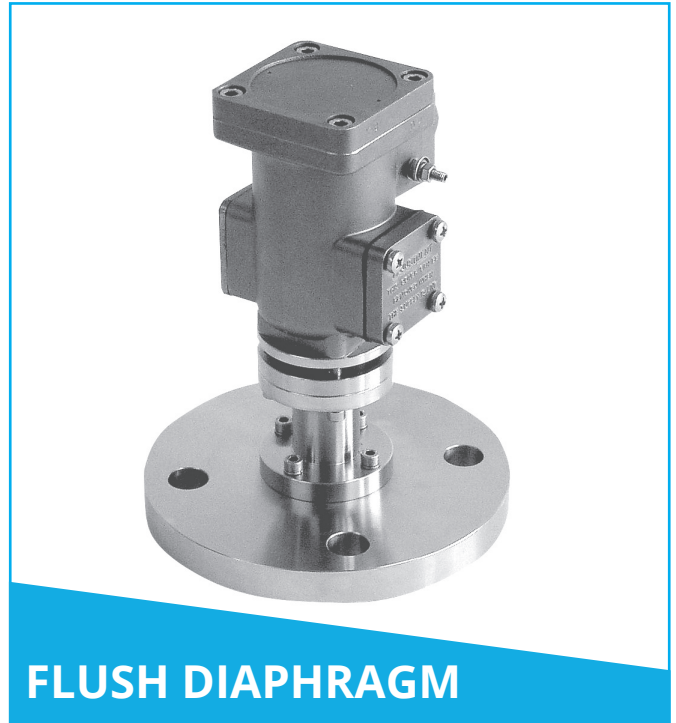

**FLUSH DIAPHRAGM**

## FEATURES

- ✓ 316 stainless steel or black anodised aluminium switchcase to IP66 standards.
- ✓ Settings from 0.1 to 32 bar.
- ✓ Wetted parts NACE MR-01-75 compliant.
- ✓ ATEX/IECEX Flameproof version  
CE II2G Exd IIB + H2 T6...T2 Gb  
Ta-60 to +75°C...90°C
- ✓ Internal adjustment scale.
- ✓ Single or dual microswitch option.
- ✓ SIL2 - IEC61508 proven reliability
- ✓ ATEX/IECEX Intrinsically safe version  
CE II1G Exia IIC T6...T2 Ga  
Ta -50 to +78°C...128°C

ADJUSTMENT RANGE (bar g)	ADJUSTMENT RANGE (psi)	MAX WORKING PRESSURE (bar g)	DEADBAND FIXED (bar g)	SPRING CODE	DIAPHRAGM CODE
0.1 - 3.1	2 - 44	12	< 0.35	B	32
1 - 7	15 - 105	12	< 0.7	W	32
2 - 16	30 - 230	40	< 1.6	B	15
4 - 32	60 - 460	40	< 3.2	W	15

## PART NUMBER BREAKDOWN

**B** = ATEX/IECEX Exd CERTIFIED  
**O** = ATEX/IECEX Exia CERTIFIED  
**A** = INDUSTRIAL

**A** = ALUMINIUM CASE  
**S** = ST. STEEL CASE

**1** = STANDARD

**DIAPHRAGM MATERIAL**  
**2** = VITON (STANDARD)  
**1** = NITRILE

**SPRING CODE**  
 (SEE RANGE TABLE ON  
 PREVIOUS PAGE)

**X** = COVER PLATE (STANDARD)

**ELECTRICAL ENTRY**

**A** = M20 STRAIGHT  
**B** = M20 ANGLED  
**C** = 1/2" NPT STR.  
**F** = M25 STRAIGHT

**P F 2 6 1 S 1 B / 2 B F 1 5 / 1 5 F S 2 X A**

**1** = 1 x SPDT SWITCH  
**2** = 2 x SPDT SWITCH

**DIAPHRAGM CODE**

DUAL SWITCHES ARE MECHANICALLY  
 LINKED TO PROVIDE DPDT SWITCHING  
 ACTION

**FS2** = DN50 FLANGE PN40 DRILLINGS TO BS  
 EN 1092-1 (REPLACES BS4504)  
 DEPTH OF FLANGE INCREASED TO ALLOW  
 FOR HIGHER PRESSURE & TEMPERATURE  
 RATING  
**FS3** = ANSI FLANGE 150#  
**FS4** = ANSI FLANGE 300#

NOTE: RESISTORS ARE INDICATED BY THE PREFIX "PR" IN PLACE OF "PF"

## SPECIFICATION

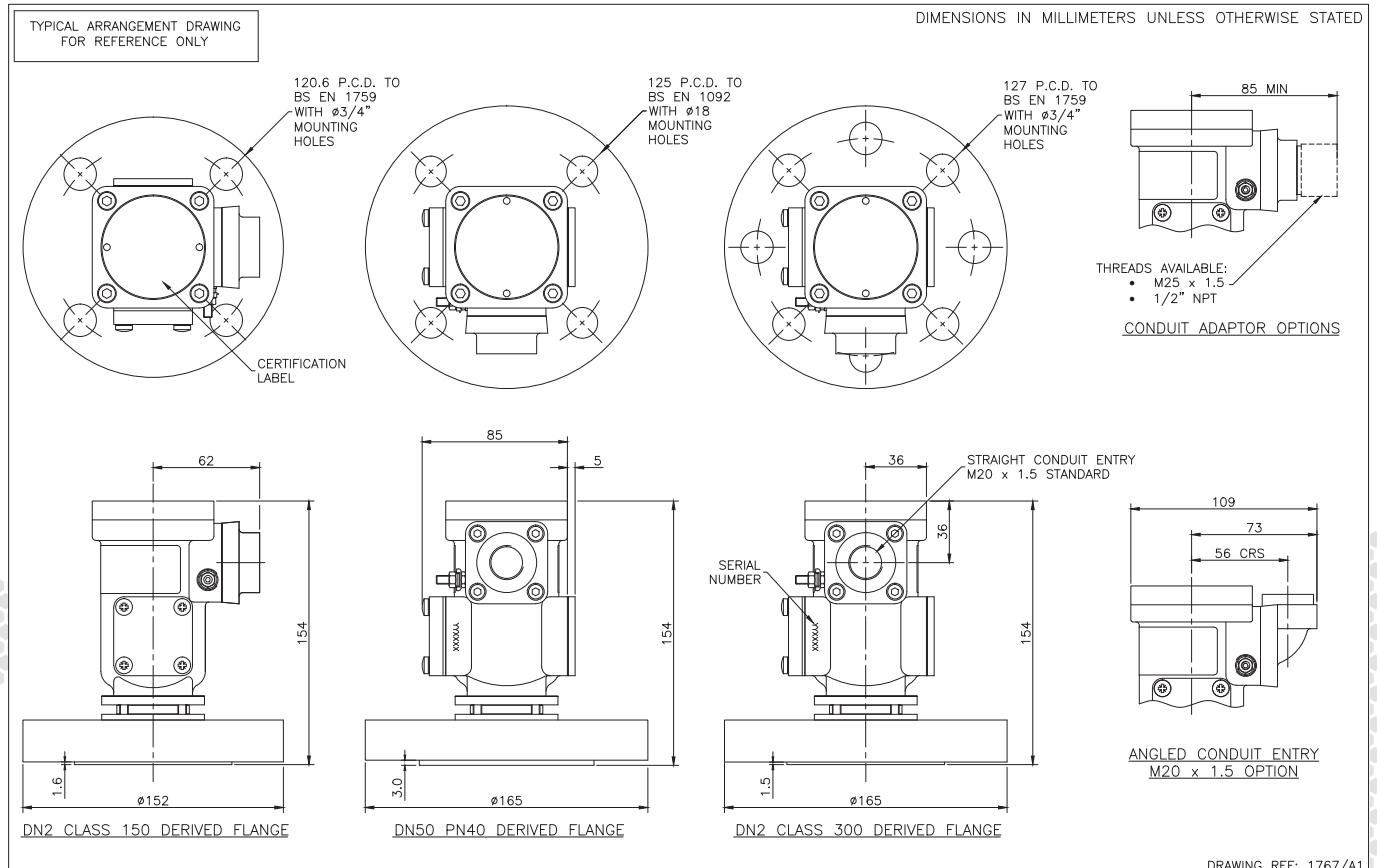

# TITAN (XPB) ATEX & IECEx Exd, Exia

## INDUSTRIAL SWITCHES

### INTRODUCTION

The Titan **pressure, differential pressure, temperature, level and flow** switches are designed for use in environments where explosive gases can be present (e.g. Gas fields, Oil rigs and Chemical plants etc.) and have been ATEX and IECEx certified as detailed overleaf. (SIL 2 - IEC61508 proven reliability).

These switches are manufactured from a high quality casting which offers robust construction and protection to IP66 for use within heavily polluted industrial and marine environments. A special feature of the instruments is the separation of the flameproof and adjustment compartments allowing for safe on-site adjustment of the set point with power on and the switch in operation.

The TITAN Exd certified switches must be installed in accordance with BS EN 60079-14. The certification allows for mounting against a wall or bulkhead with the minimum flamepath distances specified not being applicable.

### CALIBRATION

The design features a simple form of calibration adjustment against a scale plate. This allows users to either order units with a specific setting, or stock a mid range setting and then adjust to suit the application. This can be set safely with the switch supply live. On removal of the adjustment cover the adjusting ring can be turned with a small Tommy bar or Allen key. The setting is read from the centre of the red pointer ring against the calibrated scale plate. Rotation to the left will increase the set point and to the right decrease the set point. The adjustment mechanism incorporates a friction device to ensure set point will not change under vibration conditions.

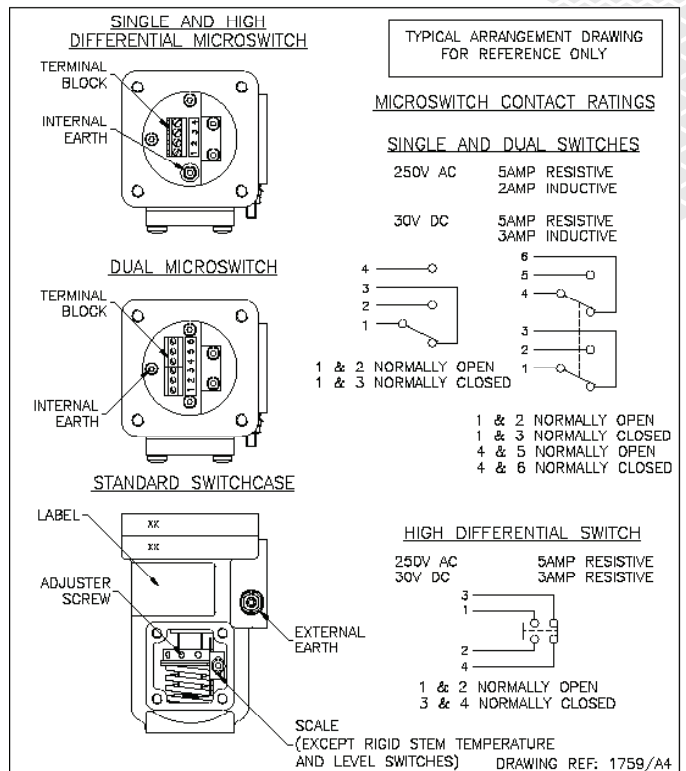

# TECHNICAL SPECIFICATION

**Switchcase and covers:** 316 stainless steel or black anodised aluminium.

**Microswitch:** 1 x SPCO/SPDT or 2 x SPCO/SPDT gold flashed silver contacts. Dual switches are mechanically linked to provide DPDT switching action, reset of switches could be up to 3% apart. Dual microswitches may increase deadband by a factor of two.

**Microswitch rating :** 5 Amps @ 250 VAC resistive, 2 Amps @ 250 VAC inductive.  
5 Amps @ 30 VDC resistive, 3 Amps @ 30 VDC inductive.

**Electrical connections :** Terminals suitable for cable 0.5 - 2.5 mm<sup>2</sup>.  
(Max 1.5mm<sup>2</sup> for dual microswitch version)

**Electrical Conduit Entry:** M20 x 1.5 straight or angled entry. ½" NPT via adaptors

**Environmental Protection:** IP66 in accordance with BS EN 60529

**Vibration and shock parameters:** Switches were subjected to Ministry of Defence Type Approval System Test Vibration DGS 350 Paras 0602 & 0603. Shock – BR3021

**Temperature Limitations:** Pressure, Vacuum and Differential Pressure.

**Process:** Diaphragm actuated (unless otherwise stated) -30 to +100°C (Nitrile) or -20 to +150°C (Viton). Piston actuated -30 to +100°C (Nitrile) or -20 to +150°C (Viton), -40 to 150°C (PTFE) or -35 to +100°C (EPDM).

**Ambient:** -50 to +85°C (standard). Storage : -60 to +85° Deg C.

(For temperature, level and flow switches please refer to specific pages).

**Certification:** Switches can be supplied for gas environments (dust must be specified at time of enquiry).

**ATEX/IECEX certified Exd Flameproof - Gas** (with or without resistors)

CE Ex II2G Exd IIB + H2T6 Ta -60 to +75°C, T5 Ta +90°C

Special conditions for safe use. 1) No modifications must be made to the flamepaths of the unit without consultation of the drawings listed on the certificate. 2) Suitably rated cable must be selected based on t Class shown above. 3) Fasteners of yield strength 240Nmm<sup>2</sup> or greater are to be utilised. 4) Only suitably certified Ex d IIC Gb cable glands are to be used.

**ATEX/IECEX certified Exia Intrinsically Safe - Gas**

CE Ex II1G Exia IIC T6 Ta -50 to +78°C, T5 Ta +93°C, T4 Ta +128°

CE Ex II1G Exia IIC T5 Ta -50 to +72°C, T4 Ta +122°C (with resistors)

Special conditions for safe use. (Category 1, Zone 0) Aluminium may only be used when the ignition hazardous assessment shows that there is no risk of ignition from incendive, impact or abraision sparks.

**Accuracy:** +/-1% at 20°C

Continuouse development may result in changes to specifications without prior notice.

## ABOUT PYROPRESS

Our products are designed to work in demanding and hazardous environments which require fast and cost effective solutions in instrumentation and control.

Pyropress control sensors provide safe and reliable electrical switching of alarm or control circuits in response to changes in temperature, pressure, differential pressure, vacuum, flow and level conditions.

## QUALITY

To support the design of state of the art products the company has invested heavily in the latest CNC technology.

We are able to produce our own components to a high degree of accuracy assuring a reliable and consistent quality product.

T: +44 (0)1752 333933 | [sales@pyropress.com](mailto:sales@pyropress.com)  
[www.pyropress.com](http://www.pyropress.com)

PPSSC1073 | issue 3