

PERSEUS

REED LEVEL

LF60 PERSEUS ATEX/ IECEX Exia & INDUSTRIAL VERTICAL REED LEVEL SWITCH

This range of magnet operated reed switches are equipped with hermetically sealed reed contacts. The float is fitted with an annular magnet which moves freely between two collars to open or close the reed contacts. As standard the wetted parts are in 316 stainless steel however they can be manufactured from different materials to suit a vast array of applications.



REED LEVEL

FEATURES



- ✓ 316 stainless steel or black anodised aluminium switchcase.
- ✓ IP66/IP67 Certified housing
- ✓ Single or dual float option
- ✓ SIL 2 - IEC 61508 proven reliability
- ✓ Custom lengths from 75 to 2000mm
- ✓ ATEX/IECEX Intrinsically Safe II 1G Ex ia IIC T6...T2 Ga Tamb -50 to +78°C...+93°C
- ✓ ATEX/IECEX Intrinsically Safe II 1D Ex ia IIIC T135°C Da Tamb -50 to +70°C

SPECIFICATIONS

Housing: 316 Stainless steel or black anodised aluminium

Wetted parts: Thread, tube, float and crimps: 316 stainless steel

Float diameter: 28mm

Process connection: 1" BSP.P or NPT with swivel adaptor for positioning

Electrical connection: DIN EN 175301-803-A plug and socket suitable for unarmoured cable, up to 1.5mm². Cable OD between 4.5 and 11mm (PG11)

M20 x 1.5 ISO female: 3 terminals suitable for cables upto 1.5mm².

M12 x 1 Circular socket: 3 contacts, A-coded plug to IEC61076-2-101.

Sealing: 316 stainless steel nitrile bonded seal

Switching level: Specified by customer +/- 5mm

Switching - SPST (standard) or SPDT. Hermetically sealed reed switch with rhodium contacts. When ordering SPST please state if contacts are to open or close at switching level.

Max. working pressure: 30 Bar (0.82SG)

Max. working temperature: 100°C

Max. voltage: 240 VAC/30 VDC*

Max. Amps: 0.5 resistive*

Max. power: 10W*

*derated for Exia applications

NOTE : DIFFERENCE BETWEEN 'L' AND LOWEST SWITCHINGPOINT IS 40 MM +/- 5MM AS STANDARD. OPTION OF 20MM +/- 5MM IS AVAILABLE FOR VERY LOW SENSING IN TANKS AND SUMPS.

CASE MATERIAL A = ANODISED ALUMINIUM S = 316 STAINLESS STEEL	CERTIFICATION 0 = ATEX/IECEx EXIA A = INDUSTRIAL/WEATHERPROOF	SWITCHING ACTION CR =CLOSE RISING OR =OPEN RISING CF =CLOSE FALLING OF =OPEN FALLING ONLY AVAILABLE WITH A SINGLE LEVEL DR =SPDT RISING DF =SPDT FALLING
	PROCESS CONNECTION 1B = 1" BSP.P MALE THREAD 1N = 1" NPT MALE THREAD	

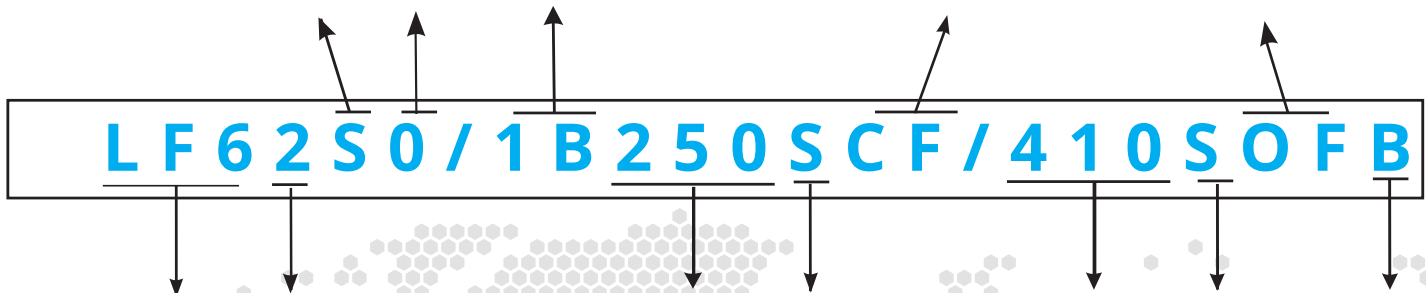

MOUNTING LF6 = VERTICAL REED LEVEL NUMBER OF FLOATS 1 = SINGLE LEVEL 2 = DUAL LEVEL	FIRST LEVEL: SWITCHING LEVEL : IN mm MEASURED UNDERNEATH HEX AS SHOWN ON DRAWING. ACCURACY +/- 5mm	SECOND LEVEL SWITCHING LEVEL : IN mm MEASURED UNDERNEATH HEX AS SHOWN ON DRAWING. ACCURACY +/- 5mm FLOAT MATERIAL S = 316 STAINLESS B = BUNA N	ELECTRICAL CONNECTION ENTRY B = RIGHT HAND SIDE L* = DUAL ENTRY T* = DUAL ENTRY TOP PLUGGED R* = DUAL ENTRY SIDE PLUGGED *STAINLESS ONLY
--	---	--	--

ALUMINIUM HOUSING

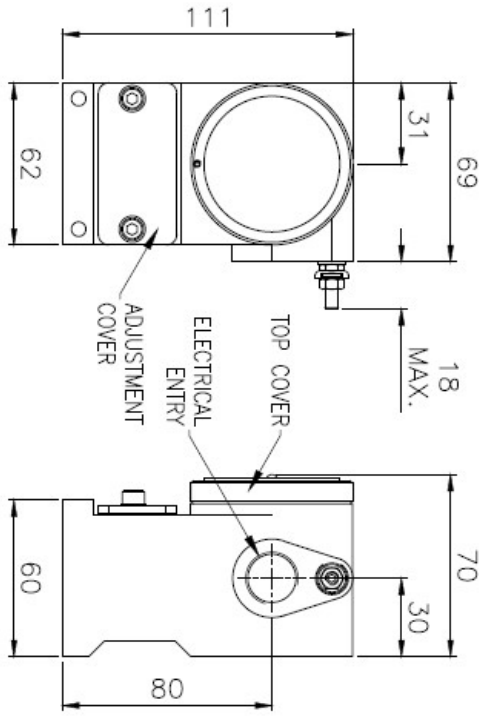

STAINLESS STEEL HOUSING

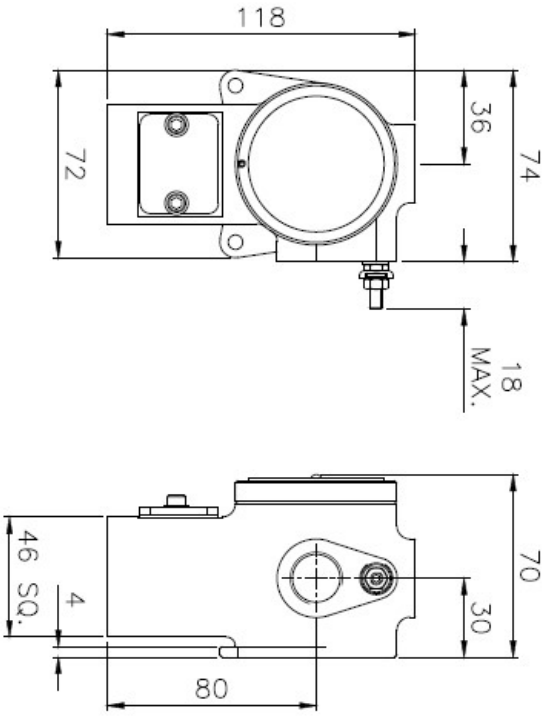

PLEASE NOTE: ALL REED LEVEL PRODUCTS ARE WIRED AS PER CUSTOMER REQUIREMENTS

DIMENSIONS IN MILLIMETRES UNLESS OTHERWISE STATED

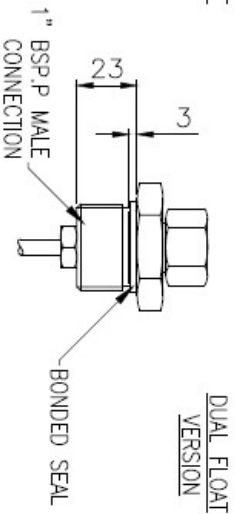
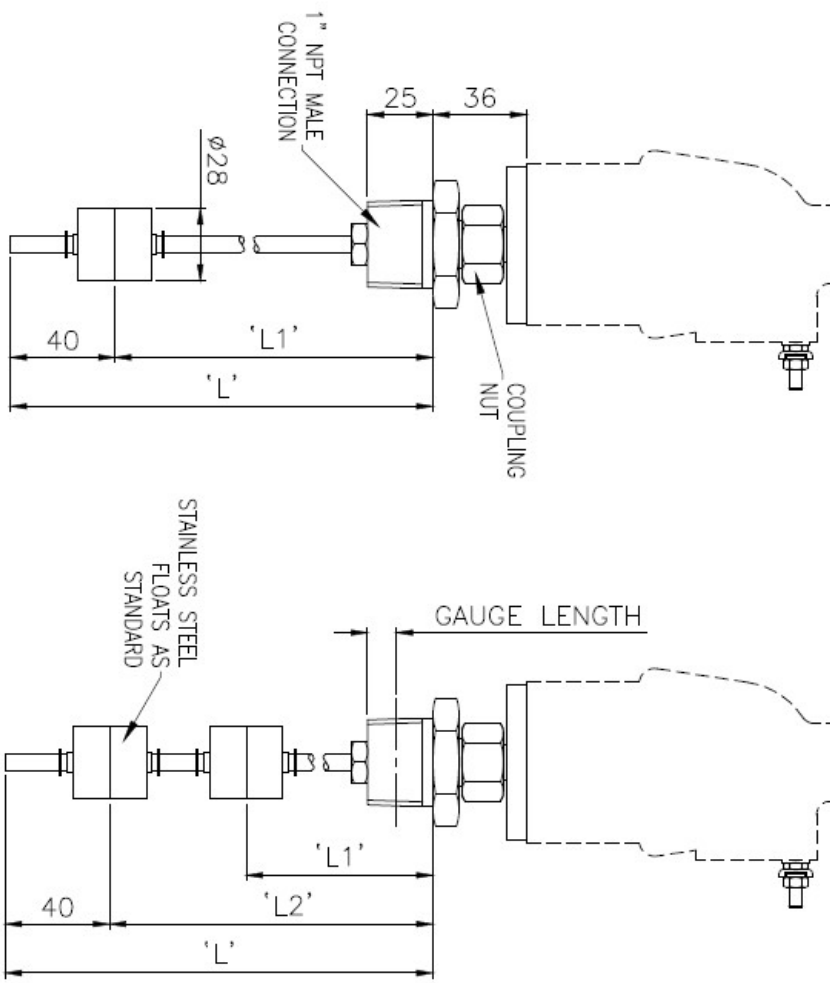

INDUSTRIAL SWITCHES

INTRODUCTION

The Perseus **pressure, vacuum, differential pressure, temperature, and level** switches are designed for use in environments where explosive gases and dust can be present (e.g. Gas fields, Oil rigs and Chemical plants etc.) and have been ATEX and IECEx certified as detailed overleaf (SIL2 - IEC 61508 proven reliability).

These switches are manufactured from a high quality casting which offers robust construction and protection to IP66 & IP67 for use within heavily polluted industrial environments. A special feature of the instruments is the separation of the flameproof and adjustment compartments allowing for safe on-site adjustment of the set point with power on and the switch in operation.

Perseus Exd switches must be installed in accordance with BS EN 60079-14

CALIBRATION

The design features a simple form of adjustment against a calibrated scale. This enables a user to order switches set at a predetermined point or stock a mid range setting and adjust switches to suit the particular application. The set point can be safely adjusted with the switch electrically live. Adjustment is made by removing the access cover and rotating the set point adjuster using a suitable tommy bar or allen key. The setting is read from the centre of the set point adjuster against the scale. Rotation to the left will increase the set point and to the right decrease it.

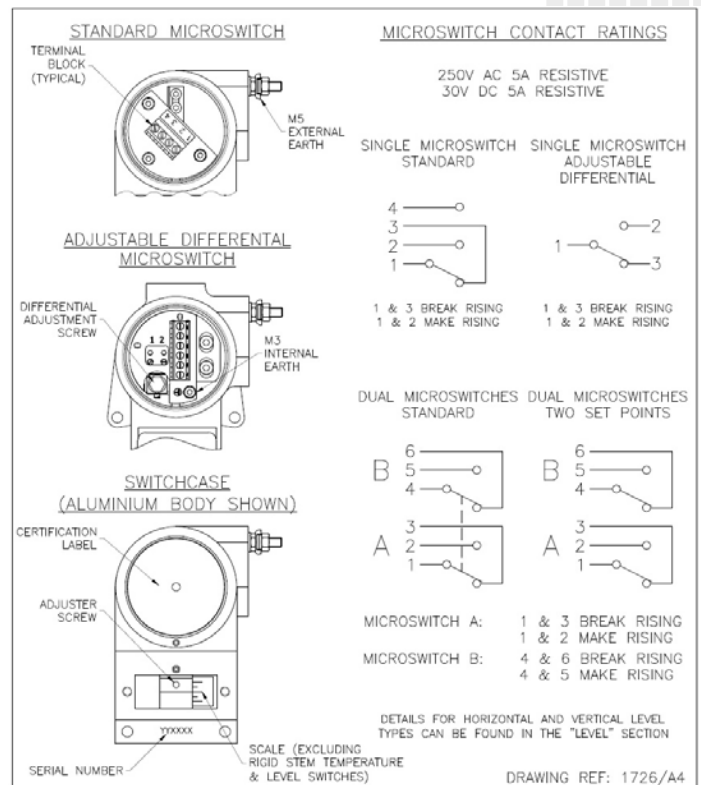

Perseus Stainless steel switchcase with dual electrical connection option

TECHNICAL SPECIFICATION

Switchcase & covers: 316 Stainless steel or black anodised aluminium case and 316 stainless steel adjustment cover.

Microswitch: 1 x SPCO/SPDT or 2 x SPCO/SPDT gold flashed silver contacts. Single switch is available with adjustable deadband option. Dual switches are either mechanically linked to provide DPDT switching action (reset of switches could be up to 3% apart) or independently adjustable. Microswitches are environmentally sealed as standard, hermetically sealed can be supplied as an option. Dual microswitches may increase deadband by a factor of two.

Microswitch rating: 5 Amps @ 250 VAC resistive, 2 Amps @ 250VAC inductive
5 Amps @ 30VDC resistive, 3 Amps @ 30 VDC inductive

Electrical Connections: Terminals suitable for cable 0.5 - 2.5 mm². (Max 1.5 mm² for dual microswitch version)

Electrical Conduit Entry: One or two M20 x 1.5 ISO. ½" NPT or M25 via adaptors

Environmental Protection: IP66 & IP67 in accordance with BS EN 60529 : 1992 & IEC 60529 : 2001.

Vibration and shock parameters: Switches were subjected Lloyds Register Test Specification 1, section 13 BS EN 60068-2-6 : 1996 (Test Fc vibration) and BS EN 60068-2-27 : 1995 (Test Ea shock).

Temperature Limitations: Pressure, Vacuum and Differential Pressure.

Process: Diaphragm actuated (unless otherwise stated) -30 to +100°C (Nitrile) or -20 to +150 Deg.C (Viton).
Piston actuated -30 to 100°C (Nitrile), -20 to +150°C (Viton), -50 to +150°C (PTFE) or -35 to +100°C (EPDM).

Ambient: -40 to +85°C.

Storage: -40 to +85 Deg.C (For temperature, level and flow switches please refer to specific pages).

ATEX/IECEX certified Exia Intrinsically Safe - Gas & dust

II 1G Ex ia IIC T6 ...T2 Ga Tamb - 50 to +78°C...+93°C

II 1 D Exia IIIC T135°C Da Ta -50 to +70°C

Special conditions for safe use. 1) For Ga installations - The equipment may be constructed using aluminium for the housing and internal parts and may only be used when the ignition hazardous assessment shows there is no risk of ignition from incendive impact or abrasion sparks.

Accuracy: +/-1% at 20°C.

Continuous development may result in changes to specification without prior notice

ABOUT PYROPRESS

Our products are designed to work in demanding and hazardous environments which require fast and cost effective solutions in instrumentation and control.

Pyropress control sensors provide safe and reliable electrical switching of alarm or control circuits in response to changes in temperature, pressure, differential pressure, vacuum, flow and level conditions.

QUALITY

To support the design of state of the art products the company has invested heavily in the latest CNC technology.

We are able to produce our own components to a high degree of accuracy assuring a reliable and consistent quality product.

T: +44 (0)1752 333933 | sales@pyropress.com
www.pyropress.com

PPSSC1094 | issue 2