

PERSEUS VERTICAL

LEVEL

LF62 PERSEUS ATEX & IECEx Exd, Exia & INDUSTRIAL LEVEL SWITCH

This range of switches features a robust high quality housing with 1 or 2 sealed SPDT microswitches and has been designed for use in environments where explosive gases can be present (e.g. gas fields, oil rigs & chemical plants etc).

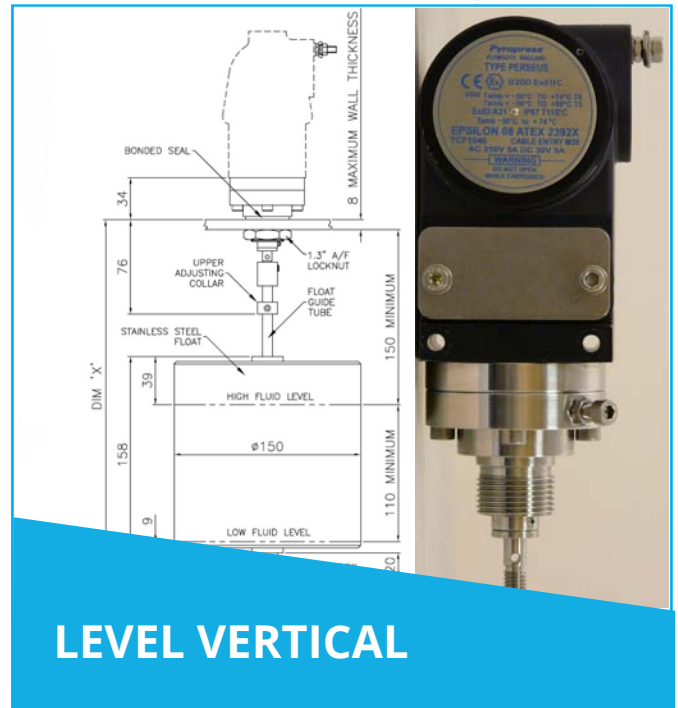

LEVEL VERTICAL

One of the benefits of the Perseus range is the separation of the flameproof and adjustment chambers allowing adjustment of the set point with power on and the switch in operation. The stainless steel housing is available with one or two electrical entries.

Type LF621 & LF622 are suitable for high or low alarms and type LF62P is suitable for pump control as it incorporates a latching mechanism. They can be installed in non-pressurised tanks and sumps with liquid temperatures upto 100°C. They can be fitted with a cover plate or flange to ease installation. The float and rod can be supplied between 260mm and 2000mm to suit application. The required length must be stated upon ordering. Each level switch is tested and adjusted individually to suit float/float rod fitted.

FEATURES



- ✓ 316 Stainless steel or black anodised aluminium switchcase to IP66 & IP67 standards.
- ✓ Wetted parts NACE MR-01-75 option
- ✓ SIL 2 - IEC61508 proven reliability.
- ✓ Single or dual microswitches option.
- ✓ Horizontal and reed level switch options available
- ✓ ATEX/IECEx Flameproof Gas & Dust version
II 2G Ex db IIC T6...T5 Gb Tamb -50°C to +75°C...+90°C
II 2D Ex tb IIIC T85°C...T100°C Db
Tamb-50°C to +75°C T85°C/-50°C to +90°C T100°C
- ✓ ATEX/IECEx Flameproof Gas version
II 2G Ex db IIC T6...T5 Gb Tamb -50°C to +75°C...+90°C
(With or without resistors)
- ✓ ATEX/IECEx Intrinsically safe Gas & Dust version
II 1G Ex ia IIC T6 ...T2 Ga Tamb - 50 to +78°C...+93°C
II 1D Ex ia IIIC T135°C Da Tamb - 50 to +70°C
(without resistors)
- ✓ ATEX/IECEx Intrinsically safe Gas version
II 1G Ex ia IIC T5...T2 Ga
(Tamb -50°C to +72°C...+122°C)
(with resistors)

PART NUMBER BREAKDOWN		ELECTRICAL CONNECTION	
MICROSWITCH OPTIONS 1 = 1 x SPDT SWITCH 2 = 2 x SPDT SWITCH P = PUMP CONTROL	SWITCHING OPTION FS001 = MICROSWITCH OPTIONS 1 & 2 ALARM FS002 = MICROSWITCH OPTION 3 PUMP CONTROL	B = RIGHT HAND SIDE L* = DUAL ENTRY TOP PLUGGED R* = DUAL ENTRY SIDE PLUGGED *STAINLESS STEEL HOUSING ONLY	
SWITCHCASE LF62 = STANDARD LR62 = WITH RESISTORS			
L F 6 2 1 A B / F S 0 0 1 S / X B _			
SWITCHCASE MATERIAL A = ALUMINIUM CASE S = STAINLESS STEEL CASE	FLOAT MATERIAL S = 316 STAINLESS STEEL	MOUNTING X = NO FLANGE OR BRACKET A = 2" ANSI 150# B = 5" ANSI 150# W = WALL MOUNTING BRACKET	ELECTRICAL CONNECTION _ = M20 LEAVE BLANK C = 1/2" NPT APARTOR. F = M25 ADAPTOR
CERTIFICATION B = ATEX/IECEX Exd CERTIFIED O = ATEX/IECEX Exia CERTIFIED A = INDUSTRIAL			

Wetted parts : 316 Stainless steel with Nitrile seals

Process connection : 3/4" BSP.P

Process temperature limitations : 0 to 100°C



ALUMINIUM HOUSING

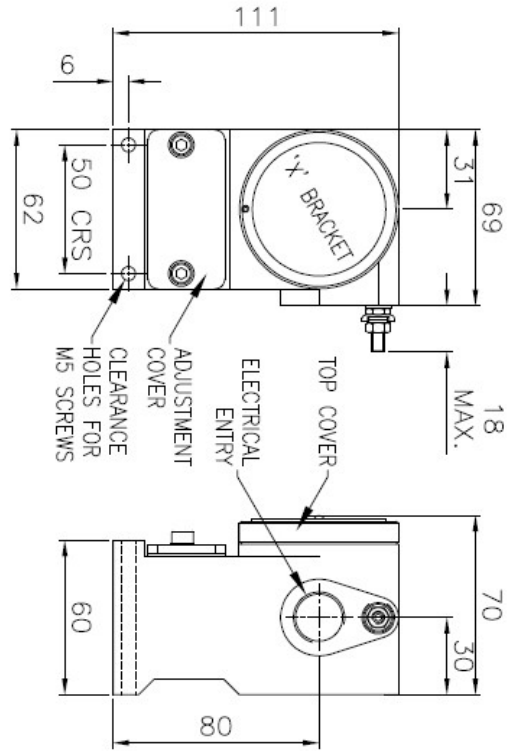

STAINLESS STEEL HOUSING

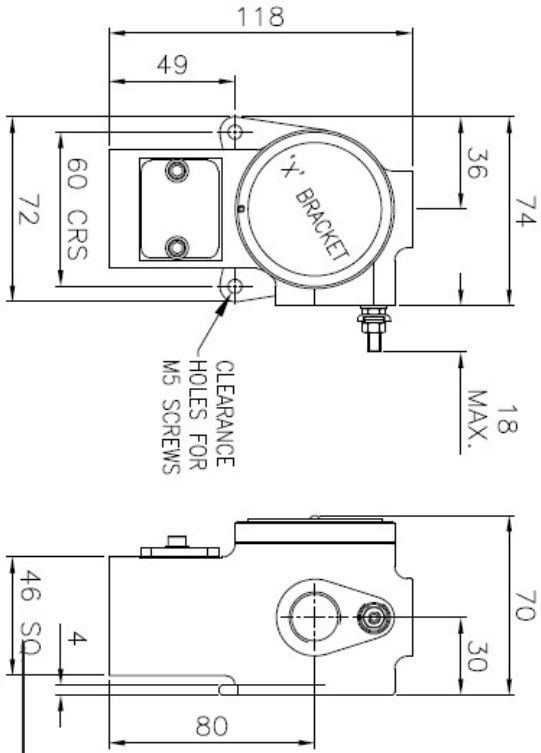

DIMENSIONS IN MILLIMETRES UNLESS OTHERWISE STATED

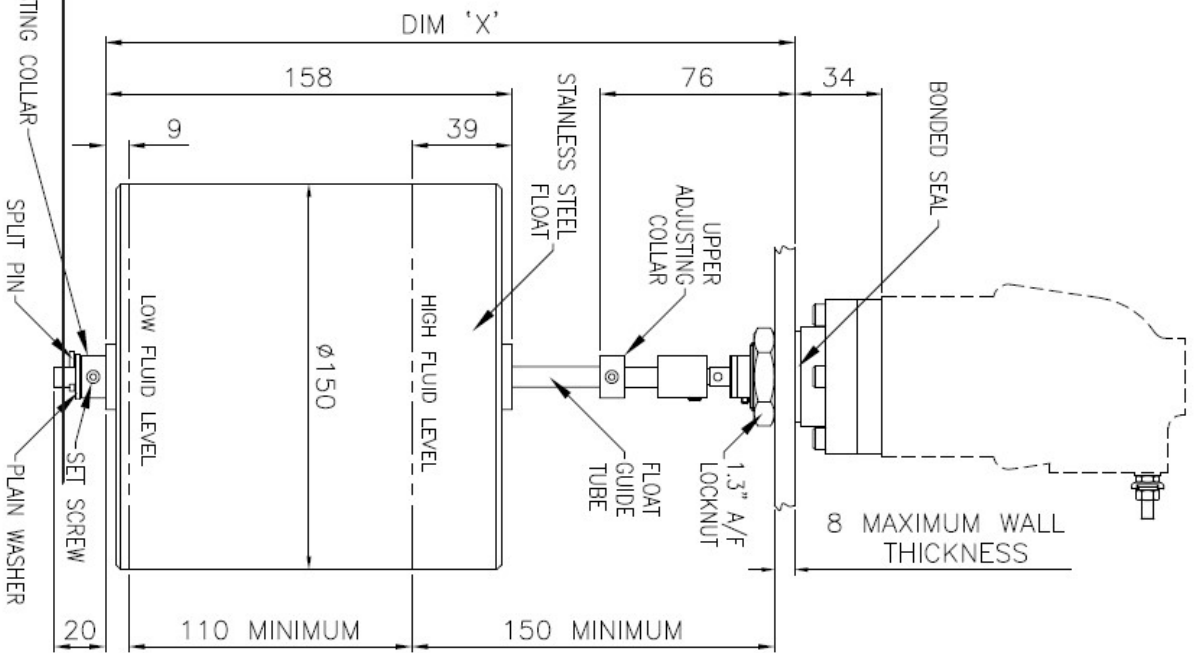

MODE A (HIGH OR LOW LEVEL ALARM)

1 & 2 (AND 4 & 5)
MAKE ON HIGH LEVEL
BREAK BELOW HIGH LEVEL

1 & 3 (AND 4 & 6)
BREAK ON HIGH LEVEL
MAKE BELOW HIGH LEVEL

MODE B (PUMP CONTROL)

1 & 3 (AND 4 & 6)
MAKE ON LOW LEVEL
REMAIN MADE UNTIL FLOAT
REACHES HIGH LEVEL
THEN BREAK

1 & 2 (AND 4 & 5)
MAKE ON HIGH LEVEL
REMAIN MADE UNTIL FLOAT
REACHES LOW LEVEL
THEN BREAK

INDUSTRIAL SWITCHES

INTRODUCTION

The Perseus **pressure, vacuum, differential pressure, temperature, and level** switches are designed for use in environments where explosive gases and dust can be present (e.g. Gas fields, Oil rigs and Chemical plants etc.) and have been ATEX and IECEx certified as detailed overleaf (SIL2 - IEC 61508 proven reliability).

These switches are manufactured from a high quality casting which offers robust construction and protection to IP66 & IP67 for use within heavily polluted industrial environments. A special feature of the instruments is the separation of the flameproof and adjustment compartments allowing for safe on-site adjustment of the set point with power on and the switch in operation.

Perseus Exd switches must be installed in accordance with BS EN 60079-14

CALIBRATION

The design features a simple form of adjustment against a calibrated scale. This enables a user to order switches set at a predetermined point or stock a mid range setting and adjust switches to suit the particular application. The set point can be safely adjusted with the switch electrically live. Adjustment is made by removing the access cover and rotating the set point adjuster using a suitable tommy bar or allen key. The setting is read from the centre of the set point adjuster against the scale. Rotation to the left will increase the set point and to the right decrease it.

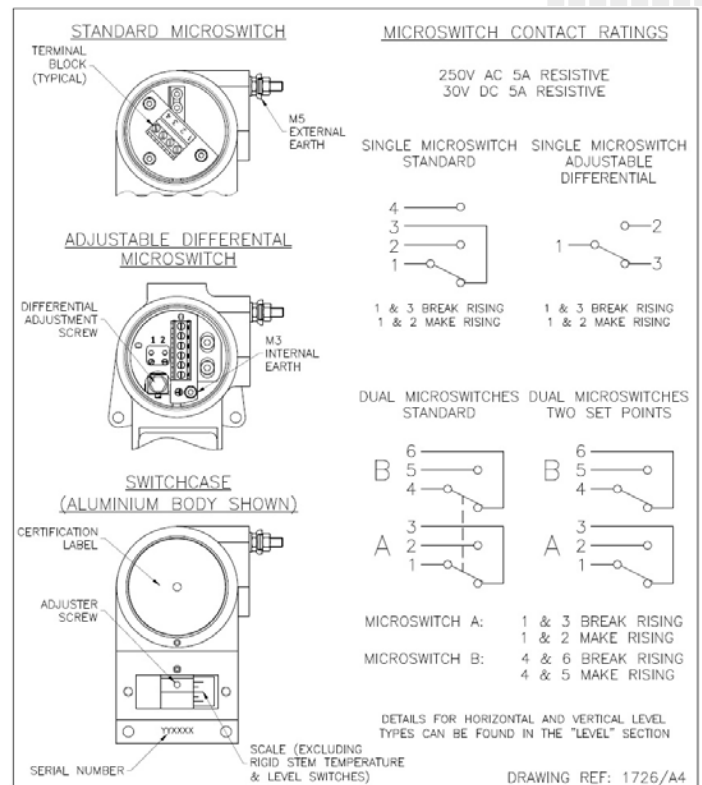

Perseus Stainless steel switchcase with dual electrical connection option

TECHNICAL SPECIFICATION

Switchcase & covers: 316 Stainless steel or black anodised aluminium case and 316 stainless steel adjustment cover.

Microswitch: 1 x SPCO/SPDT or 2 x SPCO/SPDT gold flashed silver contacts. Single switch is available with adjustable deadband option. Dual switches are either mechanically linked to provide DPDT switching action (switches could be up to 3% apart, reset levels may differ) or independently adjustable. Microswitches are environmentally sealed as standard, hermetically sealed can be supplied as an option. Dual microswitches may increase deadband.

Microswitch rating: 5 Amps @ 250 VAC resistive, 2 Amps @ 250VAC inductive

5 Amps @ 30VDC resistive, 3 Amps @ 30 VDC inductive

Electrical Connections: Terminals suitable for cable 0.5 - 2.5 mm². (Max 1.5 mm² for dual microswitch version)

Electrical Conduit Entry: One or two M20 x 1.5 ISO. ½" NPT or M25 via adaptors (2 entries only with SS housing)

Environmental Protection: IP66 & IP67 in accordance with BS EN 60529 : 1992 & IEC 60529 : 2001.

Vibration and shock parameters: Switches were subjected Lloyds Register Test Specification 1, section 13 BS EN 60068-2-6 : 1996 (Test Fc vibration) and BS EN 60068-2-27 : 1995 (Test Ea shock).

Temperature Limitations: Pressure, Vacuum and Differential Pressure.

Process: Diaphragm actuated (unless otherwise stated) -30 to +100°C (Nitrile) or -20 to +150 Deg.C (Viton).

Piston actuated -30 to 100°C (Nitrile), -20 to +150°C (Viton), -50 to +150°C (PTFE) or -35 to +100°C (EPDM).

Ambient: -40 to +85°C.

Storage: -40 to +85 °C (For temperature, level and flow switches please refer to specific pages).

ATEX & IECEx Flameproof Gas & Dust : II 2G Ex db IIC T6...T5 Gb. Tamb -50°C to +75°C...+90°C

II 2D Ex tb IIIC T85°C...T100°C Db - Tamb -50°C to +75°C T85°C/-50°C to + 90°C T100°C

ATEX & IECEx Flameproof Gas (with/without resistors) II 2G Ex db IIC T6...T5 Gb - Tamb -50°C to +75°C...+90°C T5

Special conditions for safe use. 1) Under rated conditions, the cable temperature can reach 9K above ambient temperature, ensure selection of correctly rated cable for the application. 2) Flameproof joints not intended for repair.

ATEX/IECEx Exia Intrinsically Safe Gas & dust (without resistors)

II 1G Ex ia IIC T6...T2 Ga - Tamb -50°C to +78°C...+93°C (see certificate)

II 1D Ex ia IIIC T135°C Da - Tamb -50°C to +70°C

ATEX/IECEx Exia Intrinsically Safe Gas (with resistors)

II 1G Ex ia IIC T5...T2 Ga - Tamb -50°C to +72°C...+122°C (see certificate)

Special conditions for safe use. 1) For Ga installations - The equipment may be constructed using aluminium for the housing and internal parts and may only be used when the ignition hazardous assessment shows there is no risk of ignition from incendeive impact or abrasion sparks.

Accuracy: +/-1% at 20°C.

Continuous development may result in changes to specification without prior notice

ABOUT PYROPRESS

Our products are designed to work in demanding and hazardous environments which require fast and cost effective solutions in instrumentation and control.

Pyropress control sensors provide safe and reliable electrical switching of alarm or control circuits in response to changes in temperature, pressure, differential pressure, vacuum, flow and level conditions.

QUALITY

To support the design of state of the art products the company has invested heavily in the latest CNC technology.

We are able to produce our own components to a high degree of accuracy assuring a reliable and consistent quality product.

T: +44 (0)1752 333933 | sales@pyropress.com
www.pyropress.com

PPSSC1093 | issue 3